

GROUND LEVEL COOK RM

NO SCALE

Revision	Date	Description
1	3/28/17	ADDED RVC/PHZ

Discipline	Checked By
MECHANICAL	
ELECTRICAL	
PLUMBING	
GENERAL	
SPRINKLER	

DELGROSSO FOODS, INC.
 OLD RT. 220 TIPTON, PENNSYLVANIA
 2016 STEAM SYSTEM MODIFICATIONS

Revision	Date	Description
1	3/28/17	ADDED HPC'S

Discipline	Checked By	Checked Date
MECHANICAL		
ELECTRICAL		
PLUMBING		
GENERAL CONTRACTOR		
SPRINKLER		

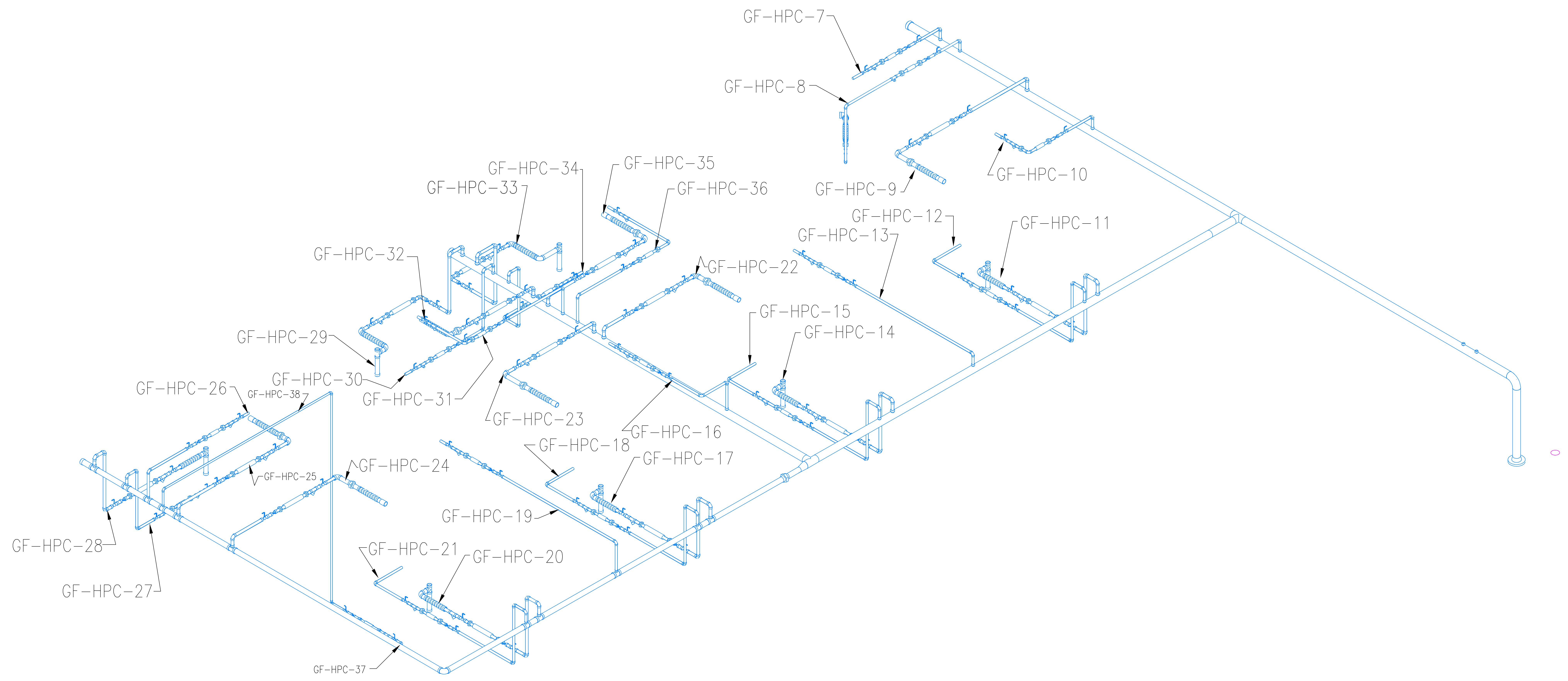

GROUND LEVEL COOK RM- HPC

NO SCALE

DELGROSSO FOODS, INC.
 OLD RT. 220 TIPTON, PENNSYLVANIA
 2016 STEAM SYSTEM MODIFICATIONS

Date: 6/14/17

Ground FLR

MAP-3

Tag	Qty	Size	Sch/Conn	Description	Length
1	1	3/4"	Schedule 80 Threaded	Pipe	6'
2	1	3/4"	Schedule 80 Threaded	Apollo 72-100 Ball Valve	
3	1	3/4"	Schedule 80 Threaded	Pipe	3'
4	1	3/4"	Schedule 80 Threaded	Wye Strainer	
5	1	3/4"	Schedule 80 Threaded	Pipe	3'
6	2	3/4"	Schedule 80 Threaded	Union	
7	1	3/4"	Schedule 80 Threaded	Pipe	3'
8	1	3/4"	Schedule 80 Threaded	Steam Trap	
9	1	3/4"	Schedule 80 Threaded	Pipe	3'
10	1	3/4"	Schedule 80 Threaded	Pipe	3'
11	1	3/4"	Schedule 80 Threaded	Milwaukee 510T Check Valve	
12	1	3/4"	Schedule 80 Threaded	Pipe	4'
13	1	3/4"	Schedule 80 Threaded	Apollo 72-100 Ball Valve	
14	1	3/4"	Schedule 80 Threaded	Pipe	11 13/16'
15	1	3/4"	Schedule 80 Threaded	90 Degree Short Radius Elbow	
16	1	3/4"	Schedule 80 Threaded	Pipe	4 15/16'

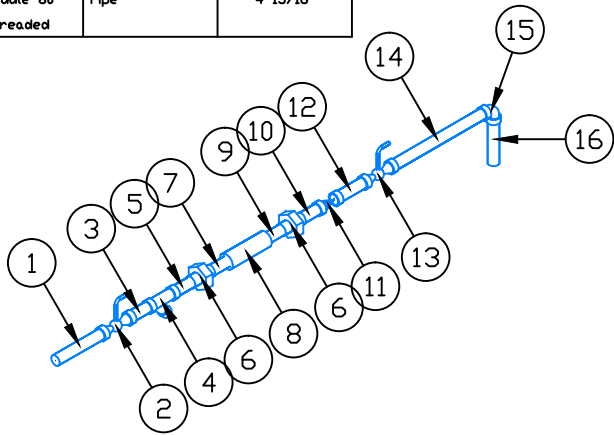

REVISIONS				
ZONE	REV	DESCRIPTION	DATE	APPROVED

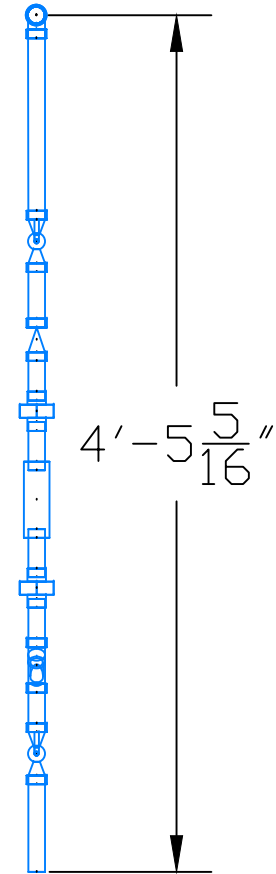

SERVICE	SHOP FABRICATE	X	STEAM,ELECT.TRACE	
HPC	FIELD FABRICATE		INSULATE	
DELGROSSD	BOILER CODE		X RAY	
REFERENCE DWG.	HEAVY WALL		STRESS RELIEF	
MAP-3	ALLOY		COLOUR CODE	
	Intrepid i Design, LLC. 503 North Twelfth Ave. Altoona, PA. 16601 Phone: (814) 941-4570 Fax: (814) 946-9776 Coordination Drawings			
	Job No	Drawing Name		Rev
	DELG17	GF-HPC-7		
DATE: 5/25/17	SIZE	SPEC		

Tag	Qty	Size	Sch/Conn	Description	Length
1	2	3/4"	Schedule 80 Threaded	Pipe	2x3'
2	3	3/4"	Schedule 80 Threaded	Union	
3	1	3/4"	Schedule 80 Threaded	Apollo 72-100 Ball Valve	
4	1	3/4"	Schedule 80 Threaded	Pipe	6 5/8"
5	3	3/4"	Schedule 80 Threaded	90 Degree Short Radius Elbow	
6	1	3/4"	Schedule 80 Threaded	Pipe	2'-4 5/8"
7	1	3/4"	Schedule 80 Threaded	Pipe	2'-3 1/4"
8	1	3/4"	Schedule 80 Threaded	Wye Strainer	
9	4	3/4"	Schedule 80 Threaded	Pipe	4x3'
10	1	3/4"	Schedule 80 Threaded	Steam Trap	
11	1	3/4"	Schedule 80 Threaded	Milwaukee 510T Check Valve	
12	1	3/4"	Schedule 80 Threaded	Pipe	4'
13	1	3/4"	Schedule 80 Threaded	Apollo 72-100 Ball Valve	
14	1	3/4"	Schedule 80 Threaded	Pipe	11 13/16"
15	1	3/4"	Schedule 80 Threaded	Pipe	4 3/4"
16	1	1-1/2"	Schedule 80 Threaded	Pipe	5 7/8"
17	1	1-1/2"	Schedule 80 Threaded	Expansion Joint	
18	1	2"	Schedule 80 Threaded	90 Degree Short Radius Elbow	

REVISIONS				
ZONE	REV	DESCRIPTION	DATE	APPROVED

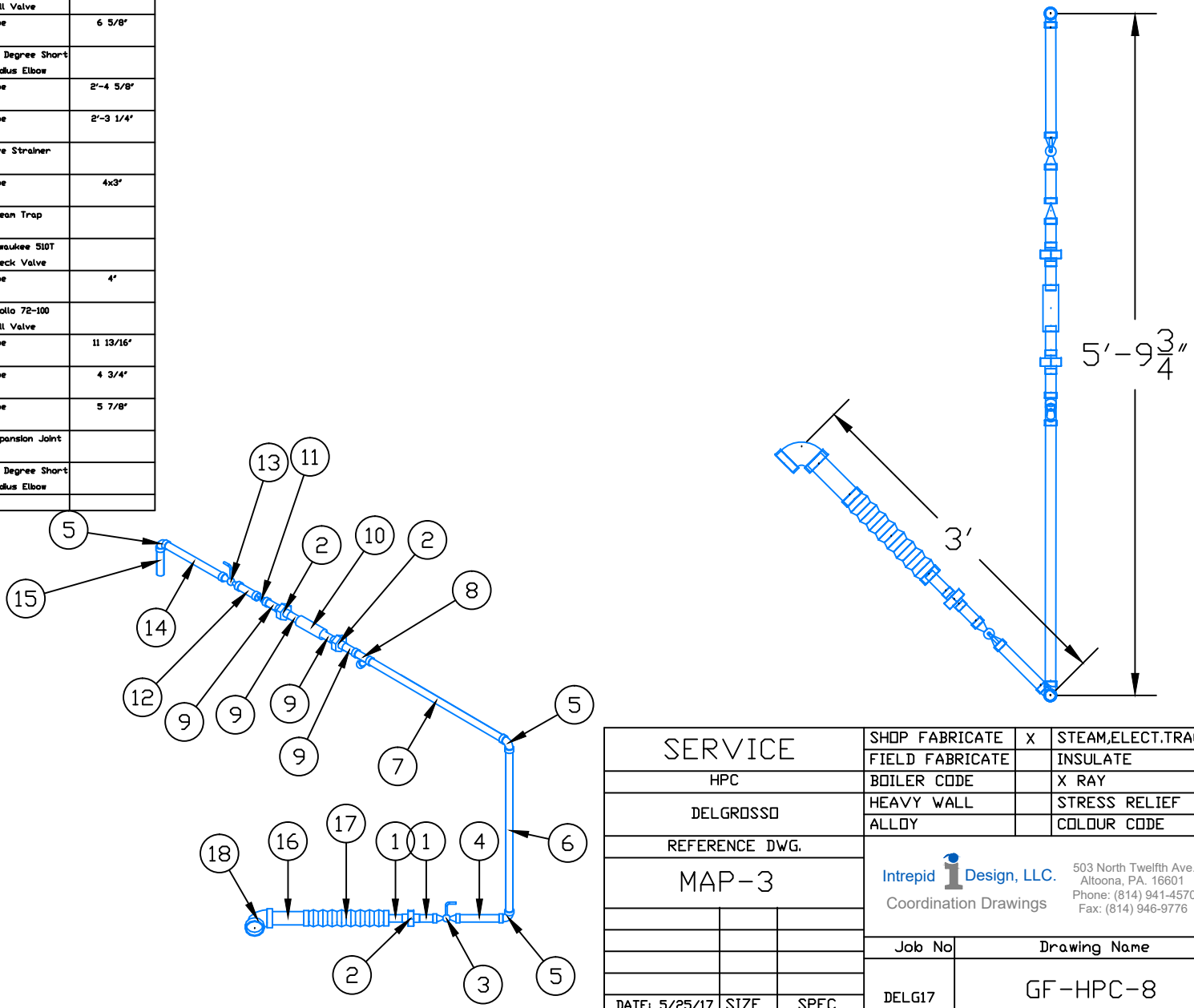

SERVICE	SHOP FABRICATE	X	STEAM,ELECT.TRACE	
HPC	FIELD FABRICATE		INSULATE	
DELGROSSO	BOILER CODE		X RAY	
REFERENCE DWG.	HEAVY WALL		STRESS RELIEF	
MAP-3	ALLOY		COLOUR CODE	
	Intrepid i Design, LLC. 503 North Twelfth Ave. Altoona, PA. 16601 Phone: (814) 941-4570 Fax: (814) 946-9776 Coordination Drawings			
	Job No	Drawing Name		Rev
	DELG17	GF-HPC-8		
DATE: 5/25/17	SIZE	SPEC		

Tag	Qty	Size	Sch/Conn	Description	Length
1	1	1"	Schedule 80 Threaded	Pipe	5 3/8'
2	1	1"	Schedule 80 Threaded	Apollo 72-100 Ball Valve	
3	6	1"	Schedule 80 Threaded	Pipe	6x3'
4	1	1"	Schedule 80 Threaded	Wye Strainer	
5	2	1"	Schedule 80 Threaded	Union	
6	1	1"	Schedule 80 Threaded	Steam Trap	
7	1	1"	Schedule 80 Threaded	Milwaukee 510T Check Valve	
8	1	1"	Schedule 80 Threaded	Apollo 72-100 Ball Valve	
9	1	1"	Schedule 80 Threaded	Pipe	2'-9 15/16'
10	1	1"	Schedule 80 Threaded	90 Degree Short Radius Elbow	
11	1	1"	Schedule 80 Threaded	Pipe	5 3/16'
12	1	1-1/2'	Schedule 80 Threaded	Coupling	
13	1	1-1/2'	Schedule 80 Threaded	Pipe	3'
14	1	1-1/2'	Schedule 80 Threaded	Expansion Joint	
15	1	1-1/2'	Schedule 80 Threaded	Pipe	4'
16	1	1-1/2'	Schedule 80 Threaded	Union	
17	1	1-1/2'	Schedule 80 Threaded	Pipe	6 3/4'
18	1	1-1/2'	Schedule 80 Threaded	90 Degree Short Radius Elbow	

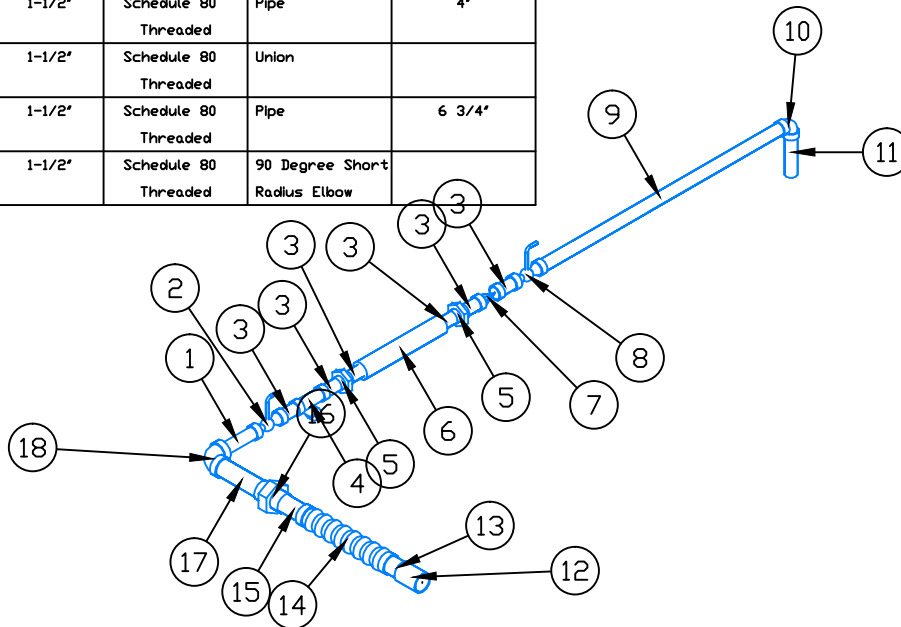

REVISIONS				
ZONE	REV	DESCRIPTION	DATE	APPROVED

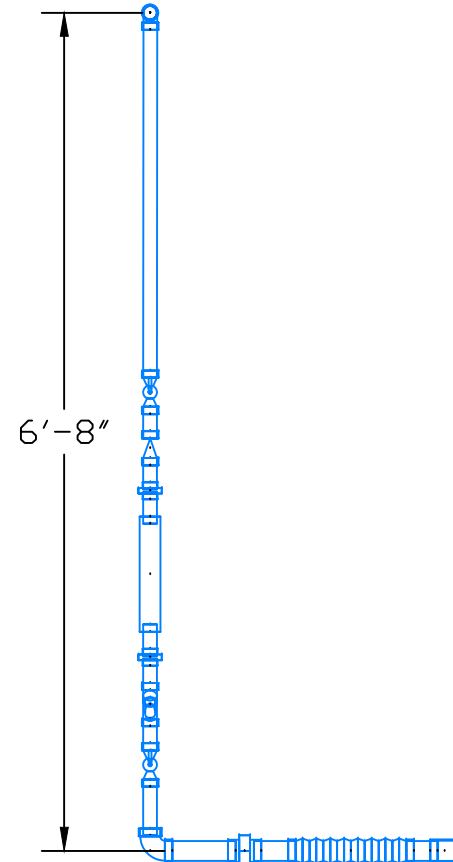

SERVICE	SHOP FABRICATE	X	STEAM,ELECT.TRACE	
HPC	FIELD FABRICATE		INSULATE	
DELGROSSD	BOILER CODE		X RAY	
	HEAVY WALL		STRESS RELIEF	
	ALLOY		COLOUR CODE	
REFERENCE DWG.	Intrepid i Design, LLC. 503 North Twelfth Ave. Altoona, PA. 16601 Phone: (814) 941-4570 Fax: (814) 946-9776			
MAP-3	Job No	Drawing Name		Rev
	DELG17	GF-HPC-9		
DATE: 5/25/17	SIZE	SPEC		

Tag	Qty	Size	Sch/Conn	Description	Length
1	2	3/4"	Schedule 80 Threaded	Pipe	2x4'
2	1	3/4"	Schedule 80 Threaded	Apollo 72-100 Ball Valve	
3	5	3/4"	Schedule 80 Threaded	Pipe	5x3'
4	1	3/4"	Schedule 80 Threaded	Wye Strainer	
5	2	3/4"	Schedule 80 Threaded	Union	
6	1	3/4"	Schedule 80 Threaded	Pipe	2 13/16'
7	2	3/4"	Schedule 80 Threaded	90 Degree Short Radius Elbow	
8	1	3/4"	Schedule 80 Threaded	Steam Trap	
9	1	3/4"	Schedule 80 Threaded	Milwaukee 510T Check Valve	
10	1	3/4"	Schedule 80 Threaded	Apollo 72-100 Ball Valve	
11	1	3/4"	Schedule 80 Threaded	Pipe	1'-3"
12	1	3/4"	Schedule 80 Threaded	Pipe	5 7/16'

REVISIONS				
ZONE	REV	DESCRIPTION	DATE	APPROVED

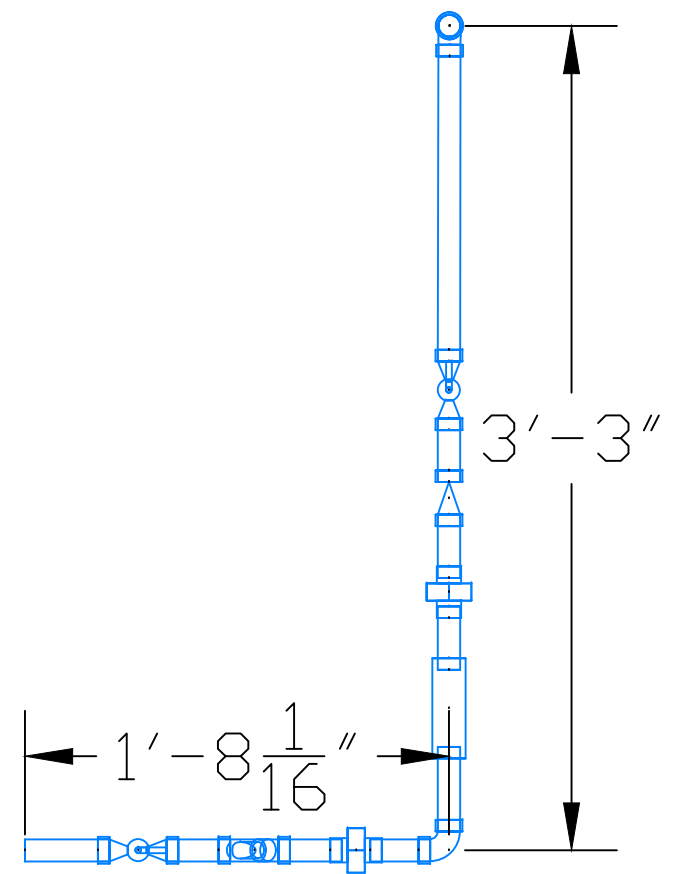
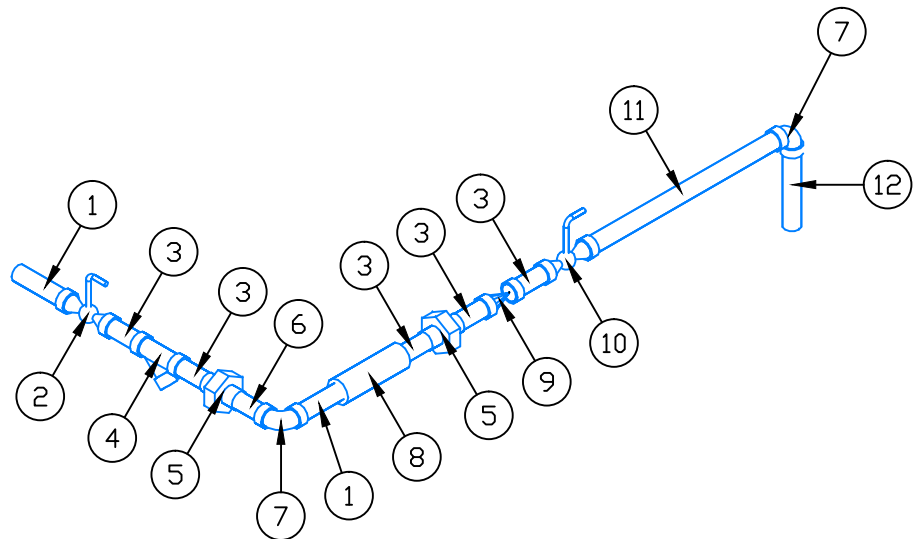

SERVICE	SHOP FABRICATE	X	STEAM,ELECT.TRACE	
HPC	FIELD FABRICATE		INSULATE	
DELGROSSD	BOILER CODE		X RAY	
	HEAVY WALL		STRESS RELIEF	
	ALLOY		COLOUR CODE	
REFERENCE DWG.	Intrepid  Design, LLC. 503 North Twelfth Ave. Altoona, PA. 16601 Phone: (814) 941-4570 Fax: (814) 946-9776			
MAP-3	Coordination Drawings			
	Job No	Drawing Name		Rev
	DELG17	GF-HPC-10		
DATE: 5/25/17	SIZE	SPEC		

Tag	Qty	Size	Sch/Conn	Description	Length
1	1	1"	Schedule 80 Threaded	Pipe	4'
2	1	1"	Schedule 80 Threaded	Apollo 72-100 Ball Valve	
3	5	1"	Schedule 80 Threaded	Pipe	5x3'
4	1	1"	Schedule 80 Threaded	Wye Strainer	
5	2	1"	Schedule 80 Threaded	Union	
6	1	1"	Schedule 80 Threaded	Steam Trap	
7	1	1"	Schedule 80 Threaded	Pipe	4 3/8'
8	1	1"	Schedule 80 Threaded	Milwaukee 510T Check Valve	
9	1	1"	Schedule 80 Threaded	Apollo 72-100 Ball Valve	
10	1	1"	Schedule 80 Threaded	Pipe	5 11/16'
11	3	1"	Schedule 80 Threaded	90 Degree Short Radius Elbow	
12	1	1"	Schedule 80 Threaded	Pipe	2'-5 9/16'
13	1	1"	Schedule 80 Threaded	Pipe	5 5/8'
14	1	1"	Schedule 80 Threaded	Pipe	5 7/16'
15	1	1-1/2"	Schedule 80 Threaded	Tee	
16	1	1-1/2"	Schedule 80 Threaded	Pipe	3 3/16'
17	1	1-1/2"	Schedule 80 Threaded	90 Degree Short Radius Elbow	
18	1	1-1/2"	Schedule 80 Threaded	Pipe	3'
19	1	1-1/2"	Schedule 80 Threaded	Expansion Joint	
20	1	1-1/2"	Schedule 80 Threaded	End Cap	
21	1	1-1/2"	Schedule 80 Threaded	Pipe	10"

REVISIONS				
ZONE	REV	DESCRIPTION	DATE	APPROVED

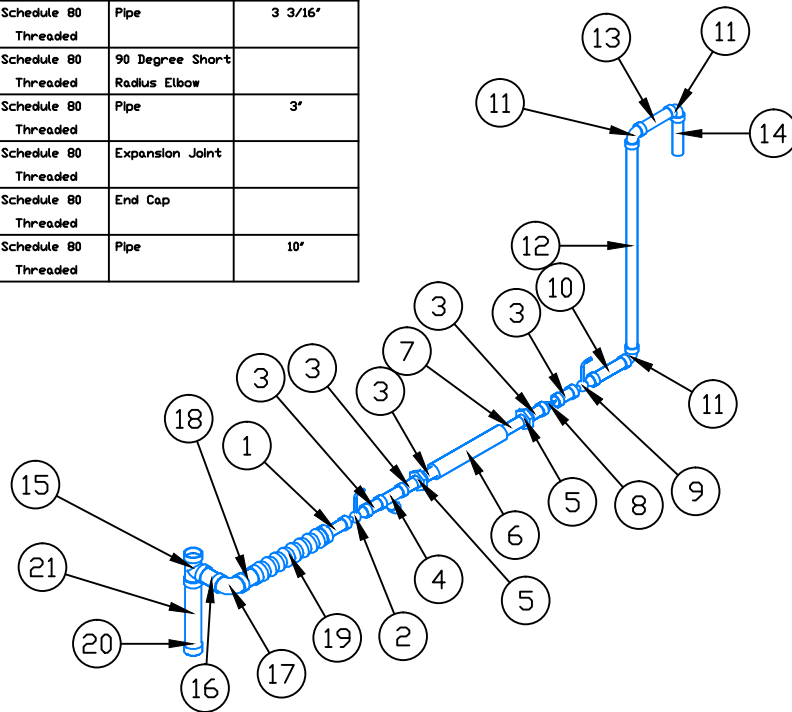
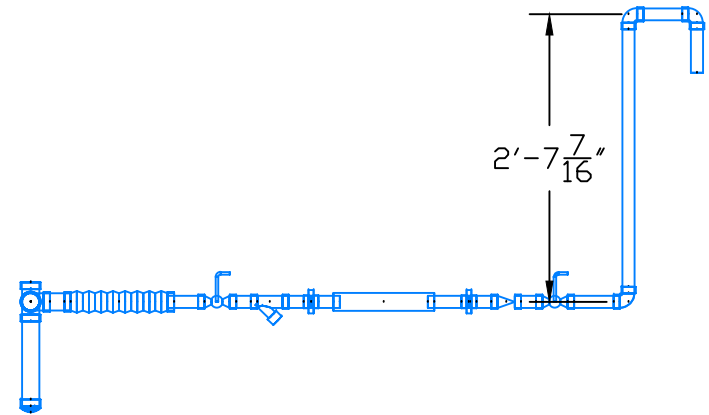
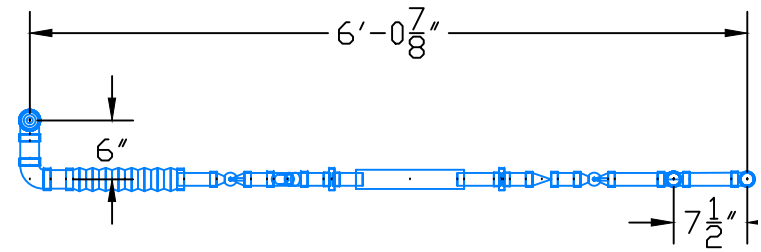

SERVICE	SHOP FABRICATE	X	STEAM,ELECT.TRACE	
HPC	FIELD FABRICATE		INSULATE	
DELGROSSD	BOILER CODE		X RAY	
REFERENCE DWG.	HEAVY WALL		STRESS RELIEF	
MAP-3	ALLOY		COLOUR CODE	
	Intrepid i Design, LLC. 503 North Twelfth Ave. Altoona, PA. 16601 Phone: (814) 941-4570 Fax: (814) 946-9776			
	Job No	Drawing Name		Rev
	DELG17	GF-HPC-11		
DATE: 5/25/17	SIZE	SPEC		

Tag	Qty	Size	Sch/Conn	Description	Length
1	1	3/4"	Schedule 80 Threaded	Pipe	1'-4"
2	4	3/4"	Schedule 80 Threaded	90 Degree Short Radius Elbow	
3	1	3/4"	Schedule 80 Threaded	Pipe	1'-3 5/16"
4	1	3/4"	Schedule 80 Threaded	Apollo 72-100 Ball Valve	
5	5	3/4"	Schedule 80 Threaded	Pipe	5x3'
6	1	3/4"	Schedule 80 Threaded	Wye Strainer	
7	1	3/4"	Schedule 80 Threaded	Pipe	5 1/16"
8	2	3/4"	Schedule 80 Threaded	Union	
9	1	3/4"	Schedule 80 Threaded	Steam Trap	
10	1	3/4"	Schedule 80 Threaded	Milwaukee 510T Check Valve	
11	1	3/4"	Schedule 80 Threaded	Apollo 72-100 Ball Valve	
12	1	3/4"	Schedule 80 Threaded	Pipe	2'-8 1/4"
13	1	3/4"	Schedule 80 Threaded	Pipe	2'-5 5/8"
14	1	3/4"	Schedule 80 Threaded	Pipe	5 3/4"
15	1	3/4"	Schedule 80 Threaded	Pipe	5 7/16"

REVISIONS				
ZONE	REV	DESCRIPTION	DATE	APPROVED

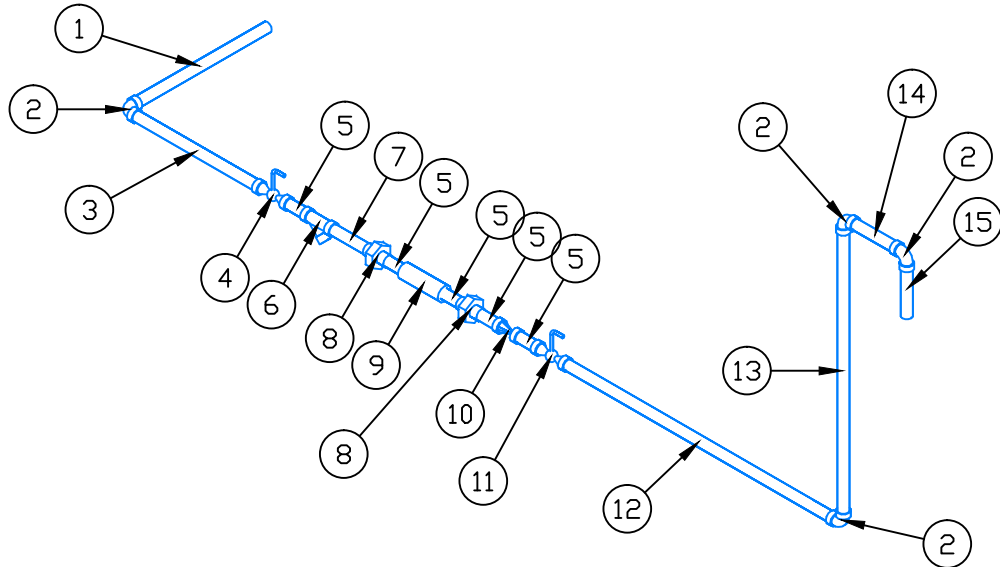
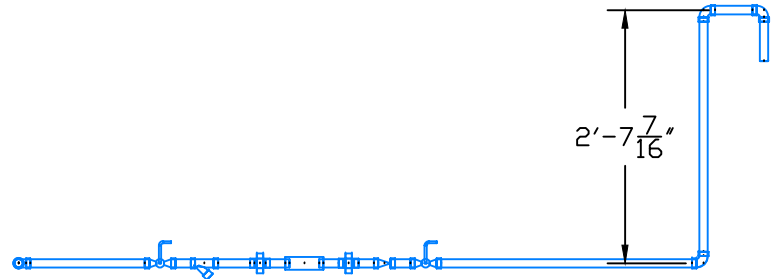
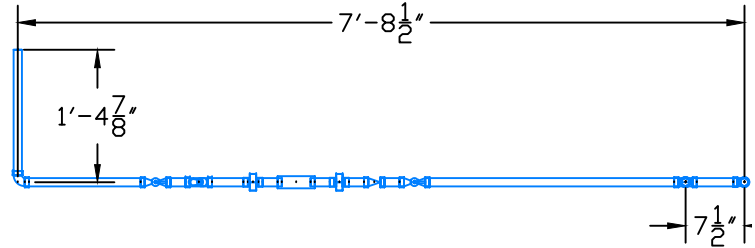

SERVICE	SHOP FABRICATE	X	STEAM,ELECT.TRACE	
HPC	FIELD FABRICATE		INSULATE	
DELGROSSO	BOILER CODE		X RAY	
REFERENCE DWG.	HEAVY WALL		STRESS RELIEF	
MAP-3	ALLOY		COLOUR CODE	
	Intrepid i Design, LLC. 503 North Twelfth Ave. Altoona, PA. 16601 Phone: (814) 941-4570 Fax: (814) 946-9776			
	Job No	Drawing Name		Rev
	DELG17	GF-HPC-12		
DATE: 5/25/17	SIZE	SPEC		

Tag	Qty	Size	Sch/Conn	Description	Length
1	1	3/4"	Schedule 80 Threaded	Pipe	4'
2	1	3/4"	Schedule 80 Threaded	Apollo 72-100 Ball Valve	
3	6	3/4"	Schedule 80 Threaded	Pipe	6x3'
4	1	3/4"	Schedule 80 Threaded	Wye Strainer	
5	2	3/4"	Schedule 80 Threaded	Union	
6	1	3/4"	Schedule 80 Threaded	Steam Trap	
7	1	3/4"	Schedule 80 Threaded	Milwaukee 510T Check Valve	
8	1	3/4"	Schedule 80 Threaded	Apollo 72-100 Ball Valve	
9	1	3/4"	Schedule 80 Threaded	Pipe	5'-10 11/16"
10	1	3/4"	Schedule 80 Threaded	90 Degree Short Radius Elbow	
11	1	3/4"	Schedule 80 Threaded	Pipe	5 1/16"

REVISIONS				
ZONE	REV	DESCRIPTION	DATE	APPROVED

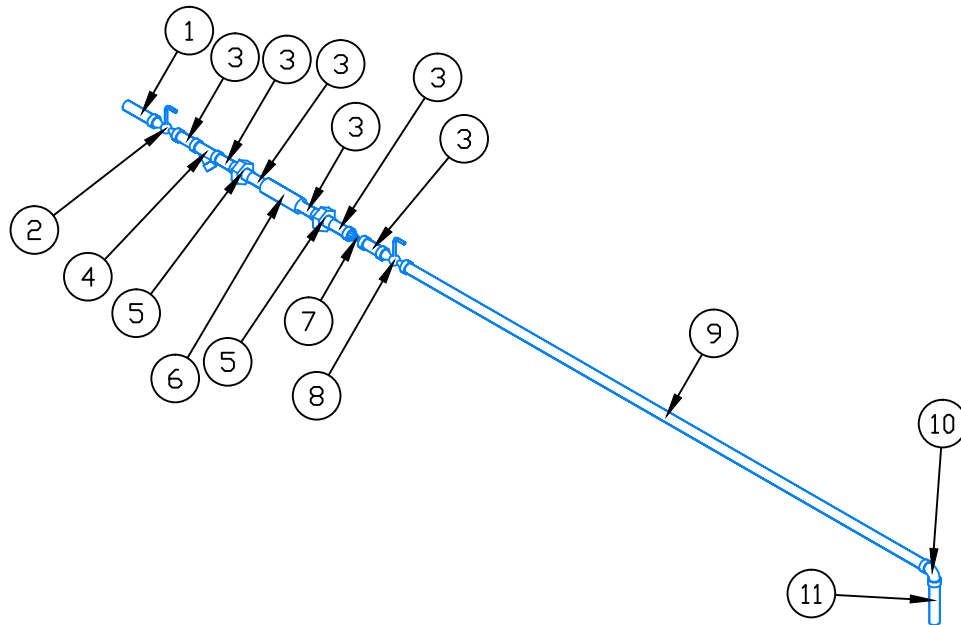
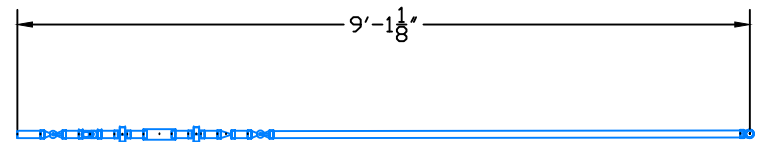

SERVICE	SHOP FABRICATE	X	STEAM,ELECT.TRACE	
HPC	FIELD FABRICATE		INSULATE	
DELGROSSD	BOILER CODE		X RAY	
REFERENCE DWG.	HEAVY WALL		STRESS RELIEF	
MAP-3	ALLOY		COLOUR CODE	
	Intrepid i Design, LLC. 503 North Twelfth Ave. Altoona, PA. 16601 Phone: (814) 941-4570 Fax: (814) 946-9776			
	Job No	Drawing Name		Rev
	DELG17	GF-HPC-13		
DATE: 5/25/17	SIZE	SPEC		

Tag	Qty	Size	Sch/Conn	Description	Length
1	1	1"	Schedule 80 Threaded	Pipe	4'
2	1	1"	Schedule 80 Threaded	Apollo 72-100 Ball Valve	
3	5	1"	Schedule 80 Threaded	Pipe	5x3'
4	1	1"	Schedule 80 Threaded	Wye Strainer	
5	2	1"	Schedule 80 Threaded	Union	
6	1	1"	Schedule 80 Threaded	Steam Trap	
7	1	1"	Schedule 80 Threaded	Pipe	4 3/8'
8	1	1"	Schedule 80 Threaded	Milwaukee 510T Check Valve	
9	1	1"	Schedule 80 Threaded	Apollo 72-100 Ball Valve	
10	1	1"	Schedule 80 Threaded	Pipe	5 11/16'
11	3	1"	Schedule 80 Threaded	90 Degree Short Radius Elbow	
12	1	1"	Schedule 80 Threaded	Pipe	2'-5 9/16'
13	1	1"	Schedule 80 Threaded	Pipe	5 9/16'
14	1	1"	Schedule 80 Threaded	Pipe	4 13/16'
15	1	1-1/2"	Schedule 80 Threaded	Tee	
16	1	1-1/2"	Schedule 80 Threaded	Pipe	3 3/16'
17	1	1-1/2"	Schedule 80 Threaded	90 Degree Short Radius Elbow	
18	1	1-1/2"	Schedule 80 Threaded	Pipe	3'
19	1	1-1/2"	Schedule 80 Threaded	Expansion Joint	
20	1	1-1/2"	Schedule 80 Threaded	End Cap	
21	1	1-1/2"	Schedule 80 Threaded	Pipe	10"

REVISIONS				
ZONE	REV	DESCRIPTION	DATE	APPROVED

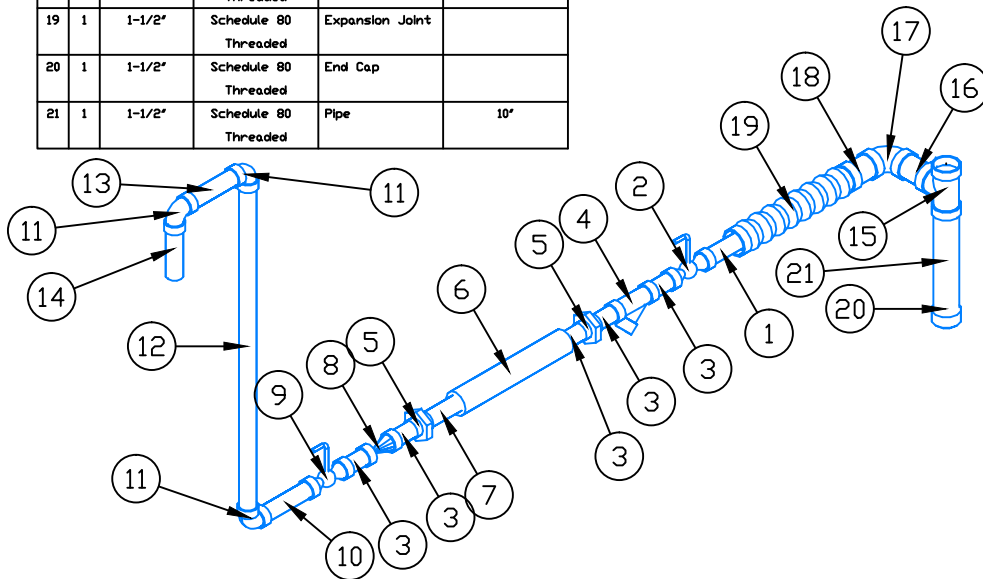
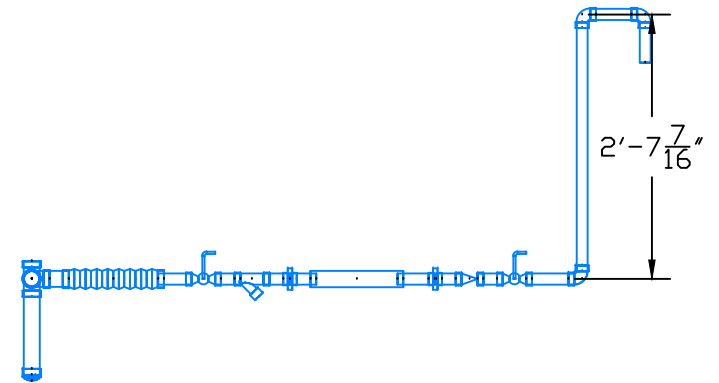
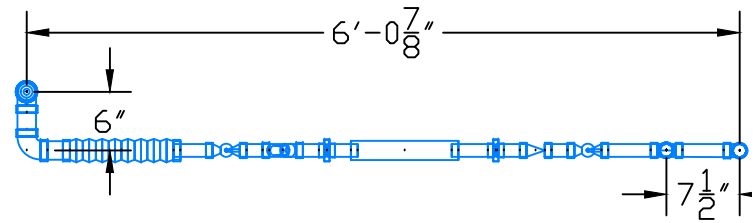

SERVICE	SHOP FABRICATE	X	STEAM,ELECT.TRACE	
HPC	FIELD FABRICATE		INSULATE	
DELGROSSD	BOILER CODE		X RAY	
REFERENCE DWG.	HEAVY WALL		STRESS RELIEF	
MAP-3	ALLOY		COLOUR CODE	
	Intrepid i Design, LLC. 503 North Twelfth Ave. Altoona, PA. 16601 Coordination Drawings Phone: (814) 941-4570 Fax: (814) 946-9776			
	Job No	Drawing Name		Rev
	DELG17	GF-HPC-14		
DATE: 5/25/17	SIZE	SPEC		

Tag	Qty	Size	Sch/Conn	Description	Length
1	1	3/4"	Schedule 80 Threaded	Pipe	1'-4"
2	4	3/4"	Schedule 80 Threaded	90 Degree Short Radius Elbow	
3	1	3/4"	Schedule 80 Threaded	Pipe	1'-3 5/16"
4	1	3/4"	Schedule 80 Threaded	Apollo 72-100 Ball Valve	
5	5	3/4"	Schedule 80 Threaded	Pipe	5x3'
6	1	3/4"	Schedule 80 Threaded	Wye Strainer	
7	1	3/4"	Schedule 80 Threaded	Pipe	5 1/16"
8	2	3/4"	Schedule 80 Threaded	Union	
9	1	3/4"	Schedule 80 Threaded	Steam Trap	
10	1	3/4"	Schedule 80 Threaded	Milwaukee 510T Check Valve	
11	1	3/4"	Schedule 80 Threaded	Apollo 72-100 Ball Valve	
12	1	3/4"	Schedule 80 Threaded	Pipe	2'-8 1/4"
13	1	3/4"	Schedule 80 Threaded	Pipe	2'-5 5/8"
14	1	3/4"	Schedule 80 Threaded	Pipe	5 3/4"
15	1	3/4"	Schedule 80 Threaded	Pipe	4 3/4"

REVISIONS				
ZONE	REV	DESCRIPTION	DATE	APPROVED

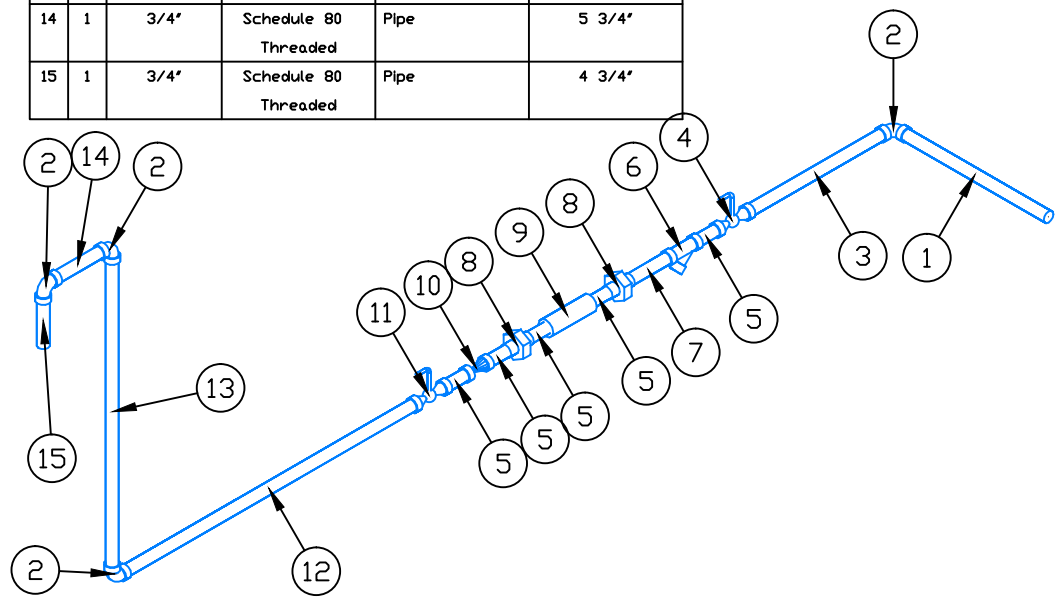
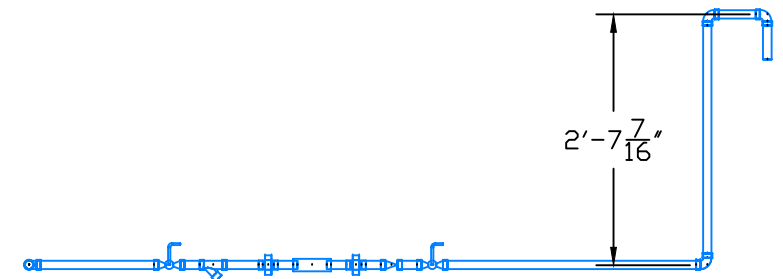
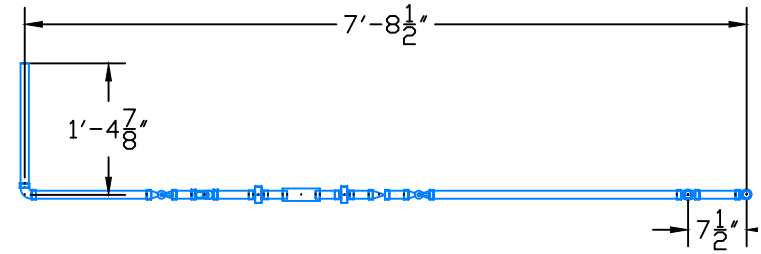

SERVICE	SHOP FABRICATE	X	STEAM,ELECT.TRACE	
HPC	FIELD FABRICATE		INSULATE	
DELGROSSD	BOILER CODE		X RAY	
	HEAVY WALL		STRESS RELIEF	
	ALLOY		COLOUR CODE	
REFERENCE DWG.	Intrepid i Design, LLC. 503 North Twelfth Ave. Altoona, PA. 16601 Phone: (814) 941-4570 Fax: (814) 946-9776			
MAP-3	Job No	Drawing Name		Rev
	DELG17	GF-HPC-15		
DATE: 5/25/17	SIZE	SPEC		

Tag	Qty	Size	Sch/Conn	Description	Length
1	1	3/4"	Schedule 80 Threaded	Pipe	4'
2	1	3/4"	Schedule 80 Threaded	Apollo 72-100 Ball Valve	
3	6	3/4"	Schedule 80 Threaded	Pipe	6x3'
4	1	3/4"	Schedule 80 Threaded	Wye Strainer	
5	2	3/4"	Schedule 80 Threaded	Union	
6	1	3/4"	Schedule 80 Threaded	Steam Trap	
7	1	3/4"	Schedule 80 Threaded	Milwaukee 510T Check Valve	
8	1	3/4"	Schedule 80 Threaded	Apollo 72-100 Ball Valve	
9	1	3/4"	Schedule 80 Threaded	Pipe	1'-5 9/16"
10	2	3/4"	Schedule 80 Threaded	90 Degree Short Radius Elbow	
11	1	3/4"	Schedule 80 Threaded	Pipe	1'-1 3/4"
12	1	3/4"	Schedule 80 Threaded	Pipe	1'-1 7/16"

REVISIONS				
ZONE	REV	DESCRIPTION	DATE	APPROVED

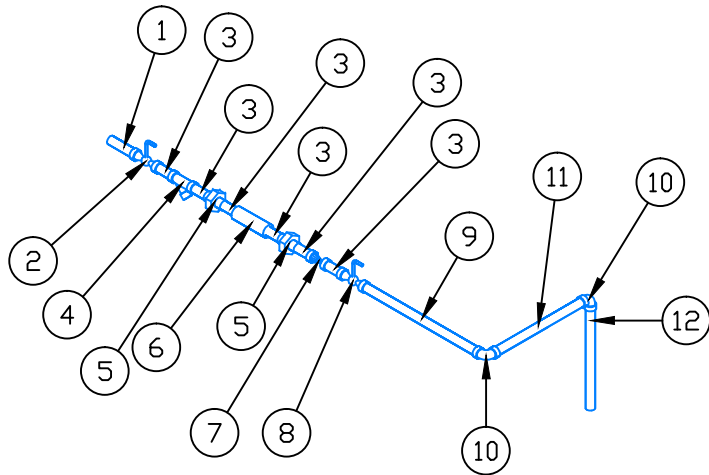
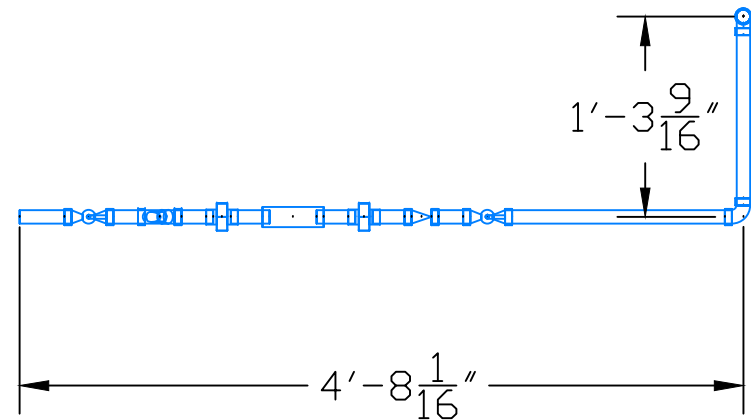

SERVICE	SHOP FABRICATE	X	STEAM,ELECT.TRACE	
HPC	FIELD FABRICATE		INSULATE	
DELGROSSO	BOILER CODE		X RAY	
REFERENCE DWG.	HEAVY WALL		STRESS RELIEF	
MAP-3	ALLOY		COLOUR CODE	
	Intrepid Design, LLC. 503 North Twelfth Ave. Altoona, PA. 16601 Coordination Drawings Phone: (814) 941-4570 Fax: (814) 946-9776			
	Job No	Drawing Name		Rev
	DELG17	GF-HPC-16		
DATE: 5/25/17	SIZE	SPEC		

Tag	Qty	Size	Sch/Conn	Description	Length																																																
1	5	1"	Schedule 80 Threaded	Pipe	5x3'																																																
2	1	1"	Schedule 80 Threaded	Apollo 72-100 Ball Valve																																																	
3	1	1"	Schedule 80 Threaded	Vye Strainer																																																	
4	1	1"	Schedule 80 Threaded	Pipe	4'																																																
5	2	1"	Schedule 80 Threaded	Union																																																	
6	1	1"	Schedule 80 Threaded	Steam Trap																																																	
7	1	1"	Schedule 80 Threaded	Pipe	4 3/8'																																																
8	1	1"	Schedule 80 Threaded	Milwaukee 510T Check Valve																																																	
9	1	1"	Schedule 80 Threaded	Apollo 72-100 Ball Valve																																																	
10	1	1"	Schedule 80 Threaded	Pipe	5 11/16'																																																
11	3	1"	Schedule 80 Threaded	90 Degree Short Radius Elbow																																																	
12	1	1"	Schedule 80 Threaded	Pipe	2'-5 9/16'																																																
13	1	1"	Schedule 80 Threaded	Pipe	5 9/16'	14	1	1"	Schedule 80 Threaded	Pipe	5 1/2'	15	1	1-1/2"	Schedule 80 Threaded	Tee		16	1	1-1/2"	Schedule 80 Threaded	Pipe	3 3/16'	17	1	1-1/2"	Schedule 80 Threaded	90 Degree Short Radius Elbow		18	1	1-1/2"	Schedule 80 Threaded	Pipe	3'	19	1	1-1/2"	Schedule 80 Threaded	Expansion Joint		20	1	1-1/2"	Schedule 80 Threaded	End Cap		21	1	1-1/2"	Schedule 80 Threaded	Pipe	10'
14	1	1"	Schedule 80 Threaded	Pipe	5 1/2'	15	1	1-1/2"	Schedule 80 Threaded	Tee		16	1	1-1/2"	Schedule 80 Threaded	Pipe	3 3/16'	17	1	1-1/2"	Schedule 80 Threaded	90 Degree Short Radius Elbow		18	1	1-1/2"	Schedule 80 Threaded	Pipe	3'	19	1	1-1/2"	Schedule 80 Threaded	Expansion Joint		20	1	1-1/2"	Schedule 80 Threaded	End Cap		21	1	1-1/2"	Schedule 80 Threaded	Pipe	10'						
15	1	1-1/2"	Schedule 80 Threaded	Tee		16	1	1-1/2"	Schedule 80 Threaded	Pipe	3 3/16'	17	1	1-1/2"	Schedule 80 Threaded	90 Degree Short Radius Elbow		18	1	1-1/2"	Schedule 80 Threaded	Pipe	3'	19	1	1-1/2"	Schedule 80 Threaded	Expansion Joint		20	1	1-1/2"	Schedule 80 Threaded	End Cap		21	1	1-1/2"	Schedule 80 Threaded	Pipe	10'												
16	1	1-1/2"	Schedule 80 Threaded	Pipe	3 3/16'	17	1	1-1/2"	Schedule 80 Threaded	90 Degree Short Radius Elbow		18	1	1-1/2"	Schedule 80 Threaded	Pipe	3'	19	1	1-1/2"	Schedule 80 Threaded	Expansion Joint		20	1	1-1/2"	Schedule 80 Threaded	End Cap		21	1	1-1/2"	Schedule 80 Threaded	Pipe	10'																		
17	1	1-1/2"	Schedule 80 Threaded	90 Degree Short Radius Elbow		18	1	1-1/2"	Schedule 80 Threaded	Pipe	3'	19	1	1-1/2"	Schedule 80 Threaded	Expansion Joint		20	1	1-1/2"	Schedule 80 Threaded	End Cap		21	1	1-1/2"	Schedule 80 Threaded	Pipe	10'																								
18	1	1-1/2"	Schedule 80 Threaded	Pipe	3'	19	1	1-1/2"	Schedule 80 Threaded	Expansion Joint		20	1	1-1/2"	Schedule 80 Threaded	End Cap		21	1	1-1/2"	Schedule 80 Threaded	Pipe	10'																														
19	1	1-1/2"	Schedule 80 Threaded	Expansion Joint		20	1	1-1/2"	Schedule 80 Threaded	End Cap		21	1	1-1/2"	Schedule 80 Threaded	Pipe	10'																																				
20	1	1-1/2"	Schedule 80 Threaded	End Cap		21	1	1-1/2"	Schedule 80 Threaded	Pipe	10'																																										
21	1	1-1/2"	Schedule 80 Threaded	Pipe	10'																																																

REVISIONS				
ZONE	REV	DESCRIPTION	DATE	APPROVED

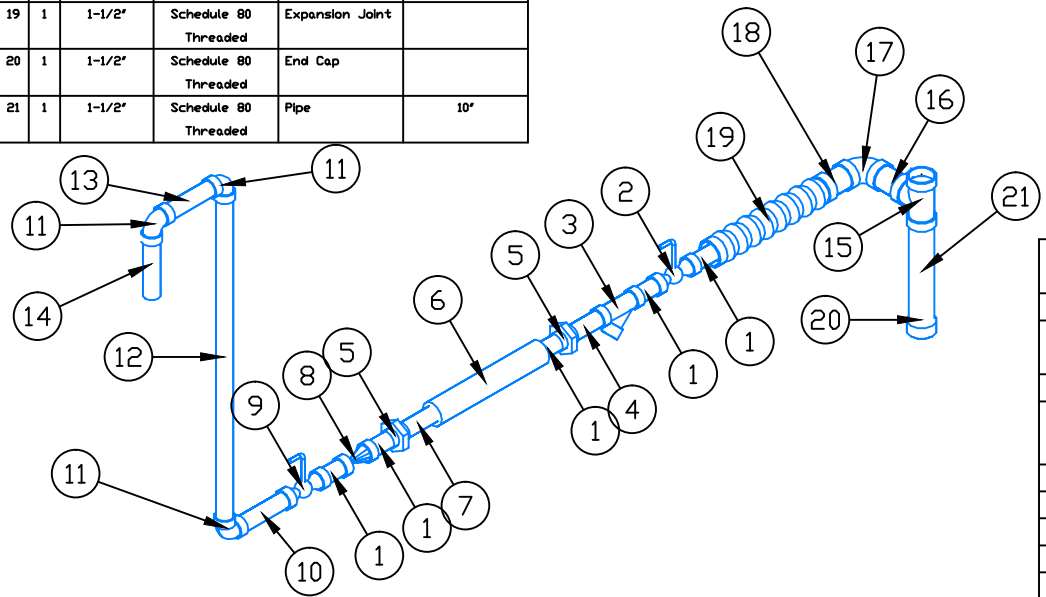
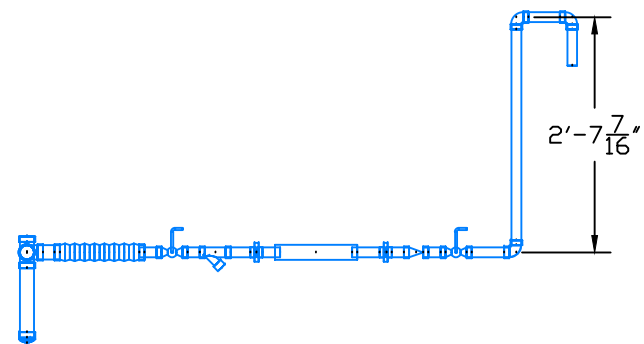
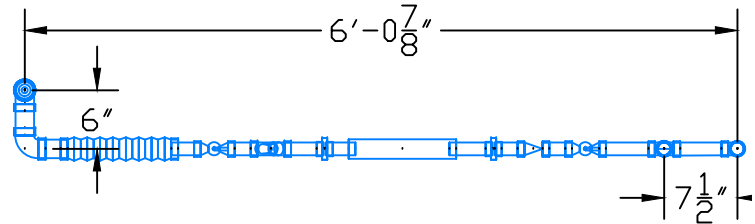

SERVICE	SHOP FABRICATE	X	STEAM,ELECT.TRACE	
HPC	FIELD FABRICATE		INSULATE	
DELGROSSO	BOILER CODE		X RAY	
REFERENCE DWG.	HEAVY WALL		STRESS RELIEF	
MAP-3	ALLOY		COLOUR CODE	
	Intrepid i Design, LLC. 503 North Twelfth Ave. Altoona, PA. 16601 Phone: (814) 941-4570 Fax: (814) 946-9776			
	Job No	Drawing Name		Rev
	DELG17	GF-HPC-17		
DATE: 5/25/17	SIZE	SPEC		

Tag	Qty	Size	Sch/Conn	Description	Length
1	1	3/4"	Schedule 80 Threaded	Pipe	1'-4"
2	4	3/4"	Schedule 80 Threaded	90 Degree Short Radius Elbow	
3	1	3/4"	Schedule 80 Threaded	Pipe	1'-4 11/16"
4	1	3/4"	Schedule 80 Threaded	Apollo 72-100 Ball Valve	
5	6	3/4"	Schedule 80 Threaded	Pipe	6x3"
6	1	3/4"	Schedule 80 Threaded	Wye Strainer	
7	2	3/4"	Schedule 80 Threaded	Union	
8	1	3/4"	Schedule 80 Threaded	Steam Trap	
9	1	3/4"	Schedule 80 Threaded	Milwaukee 510T Check Valve	
10	1	3/4"	Schedule 80 Threaded	Apollo 72-100 Ball Valve	
11	1	3/4"	Schedule 80 Threaded	Pipe	2'-8 15/16"
12	1	3/4"	Schedule 80 Threaded	Pipe	2'-5 5/8"
13	1	3/4"	Schedule 80 Threaded	Pipe	5 3/4"
14	1	3/4"	Schedule 80 Threaded	Pipe	5 1/2"

REVISIONS				
ZONE	REV	DESCRIPTION	DATE	APPROVED

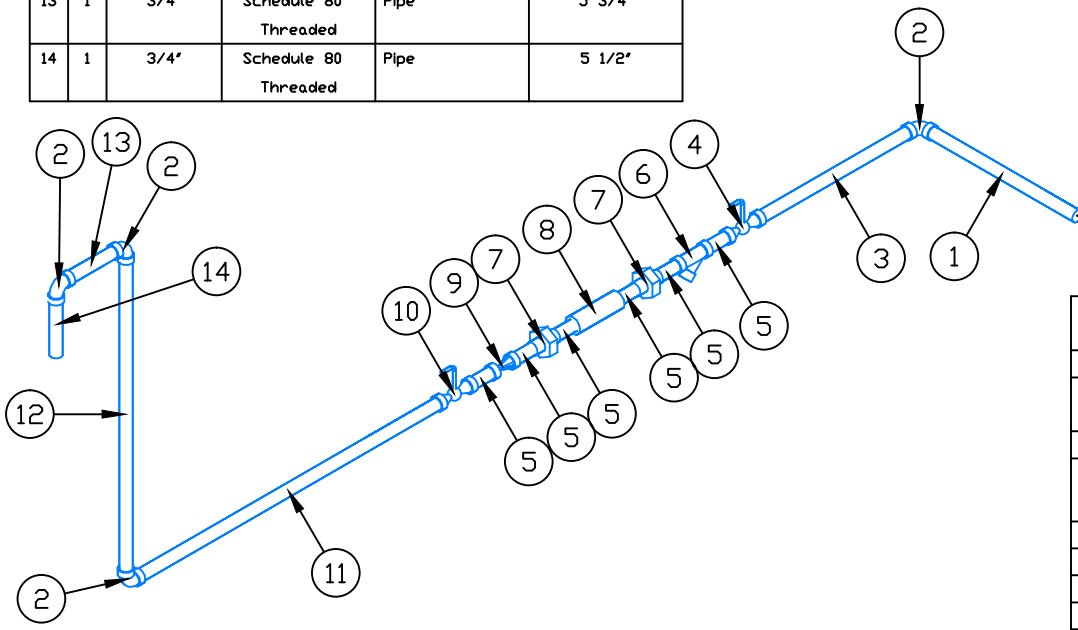
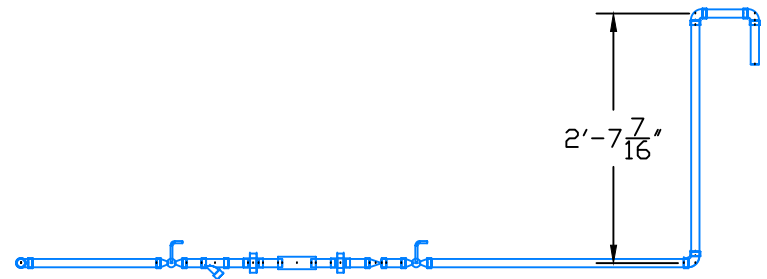
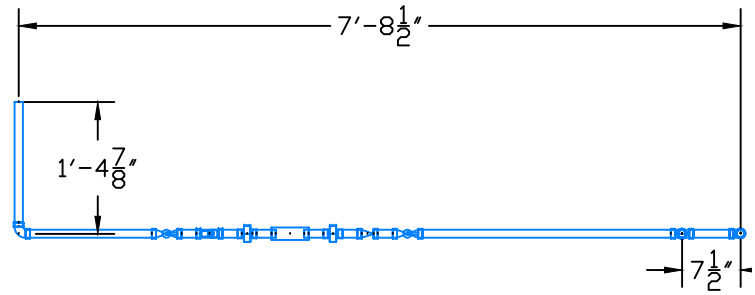

SERVICE	SHOP FABRICATE	X	STEAM,ELECT.TRACE	
HPC	FIELD FABRICATE		INSULATE	
DELGROSSO	BOILER CODE		X RAY	
	HEAVY WALL		STRESS RELIEF	
	ALLOY		COLOUR CODE	
REFERENCE DWG.	MAP-3 Intrepid  Design, LLC. 503 North Twelfth Ave. Altoona, PA. 16601 Phone: (814) 941-4570 Fax: (814) 946-9776			
	Job No	Drawing Name		Rev
	DELG17	GF-HPC-18		
DATE: 5/25/17	SIZE	SPEC		

Tag	Qty	Size	Sch/Conn	Description	Length
1	1	3/4"	Schedule 80 Threaded	Pipe	4'
2	1	3/4"	Schedule 80 Threaded	Apollo 72-100 Ball Valve	
3	6	3/4"	Schedule 80 Threaded	Pipe	6x3'
4	1	3/4"	Schedule 80 Threaded	Wye Strainer	
5	2	3/4"	Schedule 80 Threaded	Union	
6	1	3/4"	Schedule 80 Threaded	Steam Trap	
7	1	3/4"	Schedule 80 Threaded	Milwaukee 510T Check Valve	
8	1	3/4"	Schedule 80 Threaded	Apollo 72-100 Ball Valve	
9	1	3/4"	Schedule 80 Threaded	Pipe	5'-8 9/16"
10	1	3/4"	Schedule 80 Threaded	90 Degree Short Radius Elbow	
11	1	3/4"	Schedule 80 Threaded	Pipe	1'-2 3/8"

REVISIONS				
ZONE	REV	DESCRIPTION	DATE	APPROVED

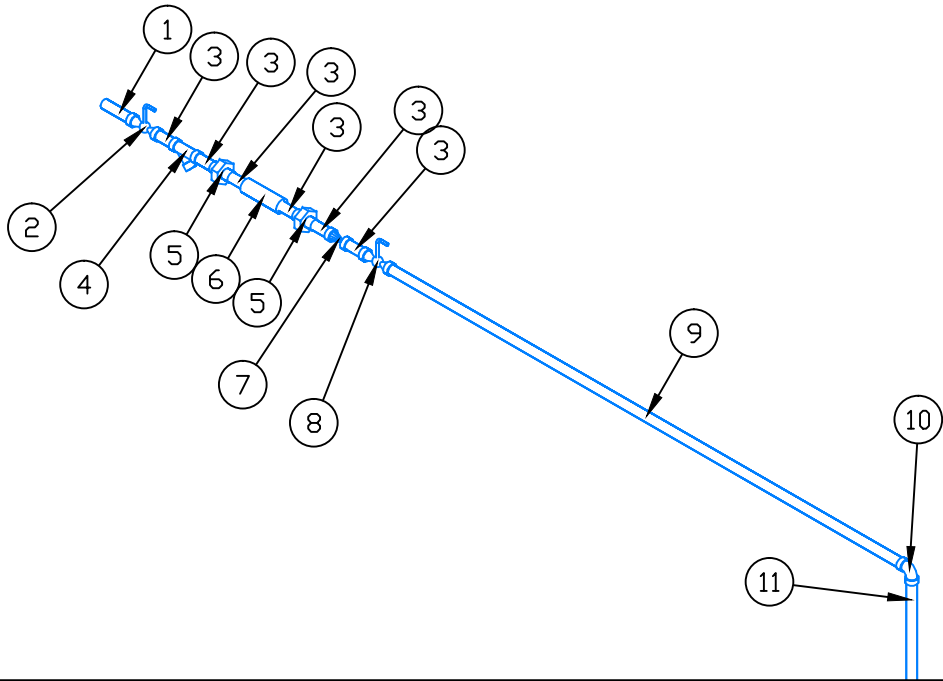
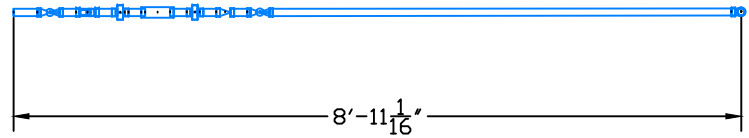

SERVICE	SHOP FABRICATE	X	STEAM,ELECT.TRACE	
HPC	FIELD FABRICATE		INSULATE	
DELGROSSD	BOILER CODE		X RAY	
	HEAVY WALL		STRESS RELIEF	
	ALLOY		COLOUR CODE	
REFERENCE DWG.	Intrepid i Design, LLC. 503 North Twelfth Ave. Altoona, PA. 16601 Phone: (814) 941-4570 Fax: (814) 946-9776			
MAP-3	Coordination Drawings			
	Job No	Drawing Name		Rev
	DELG17	GF-HPC-19		
DATE: 5/25/17	SIZE	SPEC		

Tag	Qty	Size	Sch/Conn	Description	Length
1	1	1"	Schedule 80 Threaded	Pipe	4'
2	1	1"	Schedule 80 Threaded	Wye Strainer	
3	5	1"	Schedule 80 Threaded	Pipe	5x3'
4	1	1"	Schedule 80 Threaded	Apollo 72-100 Ball Valve	
5	2	1"	Schedule 80 Threaded	Union	
6	1	1"	Schedule 80 Threaded	Steam Trap	
7	1	1"	Schedule 80 Threaded	Pipe	4 3/8'
8	1	1"	Schedule 80 Threaded	Milwaukee 5107 Check Valve	
9	1	1"	Schedule 80 Threaded	Apollo 72-100 Ball Valve	
10	1	1"	Schedule 80 Threaded	Pipe	5 11/16'
11	3	1"	Schedule 80 Threaded	90 Degree Short Radius Elbow	
12	1	1"	Schedule 80 Threaded	Pipe	2'-5 9/16'
13	1	1"	Schedule 80 Threaded	Pipe	5 9/16'
14	1	1"	Schedule 80 Threaded	Pipe	5'
15	1	1-1/2"	Schedule 80 Threaded	Tee	
16	1	1-1/2"	Schedule 80 Threaded	Pipe	3 3/16'
17	1	1-1/2"	Schedule 80 Threaded	90 Degree Short Radius Elbow	
18	1	1-1/2"	Schedule 80 Threaded	Pipe	3'
19	1	1-1/2"	Schedule 80 Threaded	Expansion Joint	
20	1	1-1/2"	Schedule 80 Threaded	End Cap	
21	1	1-1/2"	Schedule 80 Threaded	Pipe	10'

REVISIONS				
ZONE	REV	DESCRIPTION	DATE	APPROVED

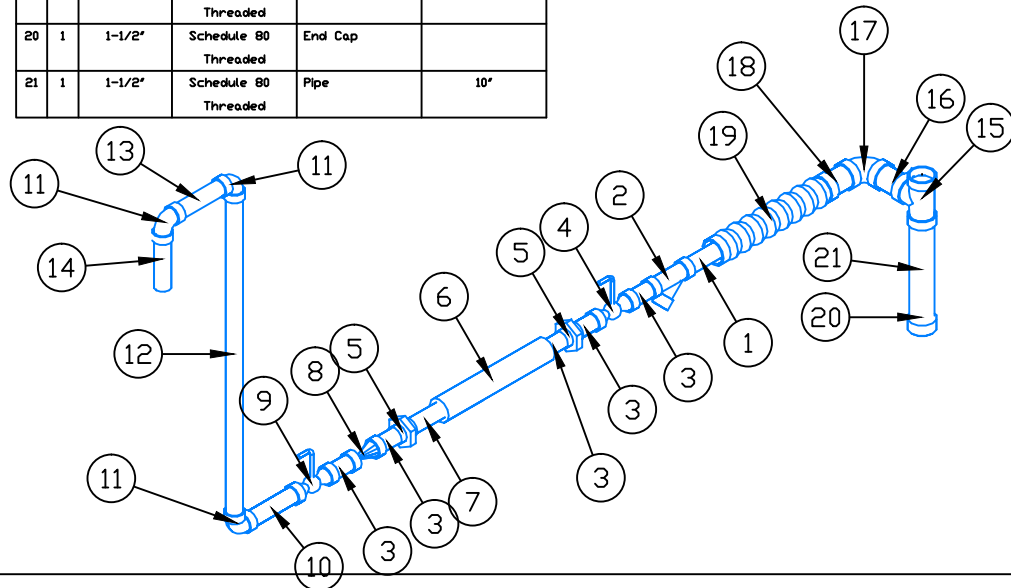
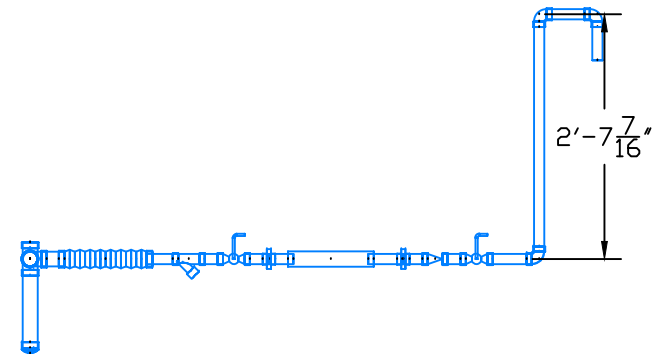
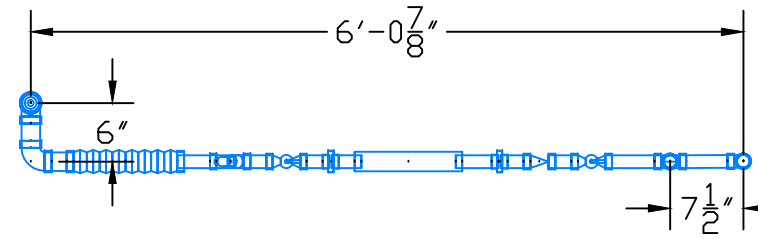

SERVICE	SHOP FABRICATE	X	STEAM,ELECT.TRACE	
HPC	FIELD FABRICATE		INSULATE	
DELGROSSD	BOILER CODE		X RAY	
	HEAVY WALL		STRESS RELIEF	
	ALLOY		COLOUR CODE	
REFERENCE DWG.	Intrepid i Design, LLC. 503 North Twelfth Ave. Altoona, PA. 16601 Phone: (814) 941-4570 Fax: (814) 946-9776			
MAP-3	Coordination Drawings			
	Job No	Drawing Name		Rev
	DELG17	GF-HPC-20		
DATE: 5/25/17	SIZE	SPEC		

Tag	Qty	Size	Sch/Conn	Description	Length
1	1	3/4"	Schedule 80 Threaded	Pipe	1'-4"
2	4	3/4"	Schedule 80 Threaded	90 Degree Short Radius Elbow	
3	1	3/4"	Schedule 80 Threaded	Pipe	1'-4 11/16"
4	1	3/4"	Schedule 80 Threaded	Apollo 72-100 Ball Valve	
5	6	3/4"	Schedule 80 Threaded	Pipe	6x3"
6	1	3/4"	Schedule 80 Threaded	Wye Strainer	
7	2	3/4"	Schedule 80 Threaded	Union	
8	1	3/4"	Schedule 80 Threaded	Steam Trap	
9	1	3/4"	Schedule 80 Threaded	Milwaukee 510T Check Valve	
10	1	3/4"	Schedule 80 Threaded	Apollo 72-100 Ball Valve	
11	1	3/4"	Schedule 80 Threaded	Pipe	2'-8 15/16"
12	1	3/4"	Schedule 80 Threaded	Pipe	2'-5 5/8"
13	1	3/4"	Schedule 80 Threaded	Pipe	5 11/16"
14	1	3/4"	Schedule 80 Threaded	Pipe	5'

REVISIONS				
ZONE	REV	DESCRIPTION	DATE	APPROVED

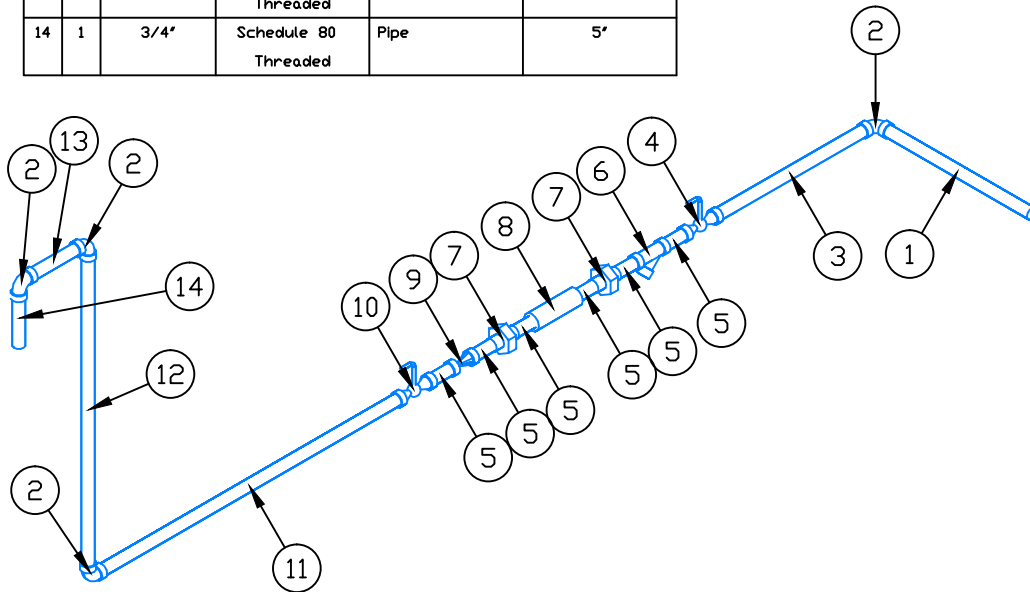
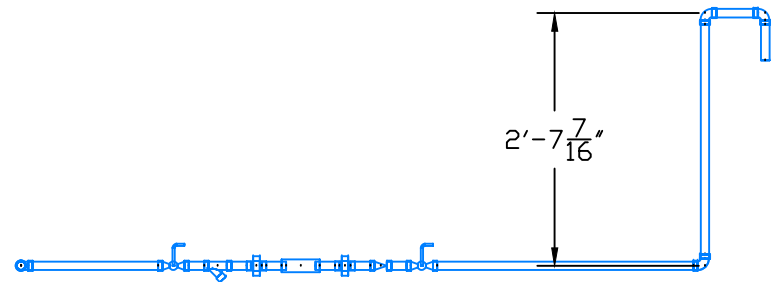
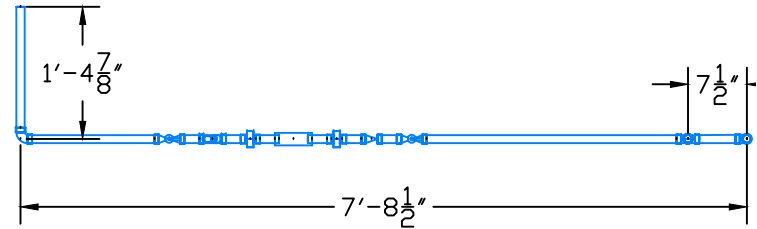

SERVICE	SHOP FABRICATE	X	STEAM,ELECT.TRACE	
HPC	FIELD FABRICATE		INSULATE	
DELGROSSO	BOILER CODE		X RAY	
	HEAVY WALL		STRESS RELIEF	
	ALLOY		COLOUR CODE	
REFERENCE DWG.	Intrepid i Design, LLC. 503 North Twelfth Ave. Altoona, PA. 16601 Phone: (814) 941-4570 Fax: (814) 946-9776			
MAP-3	Coordination Drawings			
	Job No	Drawing Name		Rev
	DELG17	GF-HPC-21		
DATE: 5/25/17	SIZE	SPEC		

Tag	Qty	Size	Sch/Conn	Description	Length
1	1	1"	Schedule 80 Threaded	Pipe	4'
2	1	1"	Schedule 80 Threaded	Apollo 72-100 Ball Valve	
3	6	1"	Schedule 80 Threaded	Pipe	6x3'
4	1	1"	Schedule 80 Threaded	Wye Strainer	
5	2	1"	Schedule 80 Threaded	Union	
6	1	1"	Schedule 80 Threaded	Steam Trap	
7	1	1"	Schedule 80 Threaded	Milwaukee 510T Check Valve	
8	1	1"	Schedule 80 Threaded	Apollo 72-100 Ball Valve	
9	1	1"	Schedule 80 Threaded	Pipe	11 3/16'
10	1	1"	Schedule 80 Threaded	90 Degree Short Radius Elbow	
11	1	1"	Schedule 80 Threaded	Pipe	3 7/8"
12	1	1-1/2"	Schedule 80 Threaded	Coupling	
13	2	1-1/2"	Schedule 80 Threaded	Pipe	2x3'
14	1	1-1/2"	Schedule 80 Threaded	Expansion Joint	
15	1	1-1/2"	Schedule 80 Threaded	Union	
16	1	1-1/2"	Schedule 80 Threaded	Pipe	4 3/4'
17	1	1-1/2"	Schedule 80 Threaded	90 Degree Short Radius Elbow	

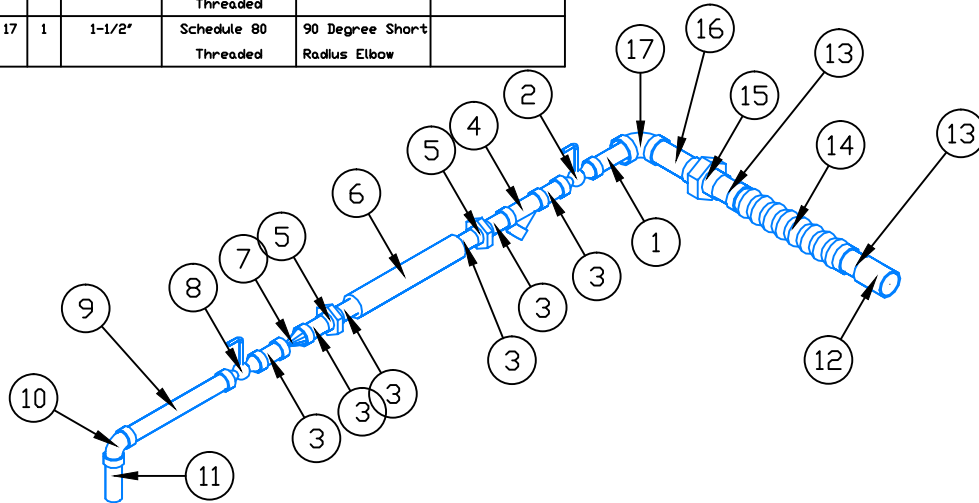

REVISIONS				
ZONE	REV	DESCRIPTION	DATE	APPROVED

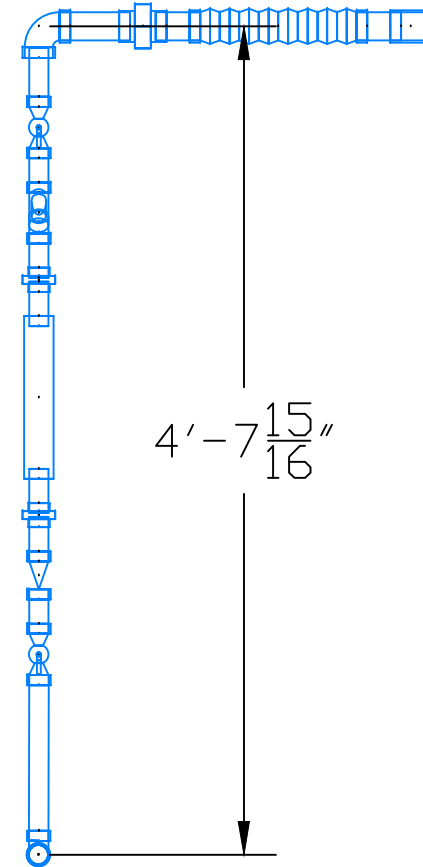

SERVICE	SHOP FABRICATE	X	STEAM,ELECT.TRACE	
HPC	FIELD FABRICATE		INSULATE	
DELGROSSD	BOILER CODE		X RAY	
	HEAVY WALL		STRESS RELIEF	
	ALLOY		COLOUR CODE	
REFERENCE DWG.	Intrepid i Design, LLC. 503 North Twelfth Ave. Altoona, PA. 16601 Phone: (814) 941-4570 Fax: (814) 946-9776			
MAP-3	Job No	Drawing Name		Rev
	DELG17	GF-HPC-22		
DATE: 5/25/17	SIZE	SPEC		

Tag	Qty	Size	Sch/Conn	Description	Length
1	1	1"	Schedule 80 Threaded	Pipe	5 3/8'
2	1	1"	Schedule 80 Threaded	Apollo 72-100 Ball Valve	
3	6	1"	Schedule 80 Threaded	Pipe	6x3'
4	1	1"	Schedule 80 Threaded	Wye Strainer	
5	2	1"	Schedule 80 Threaded	Union	
6	1	1"	Schedule 80 Threaded	Steam Trap	
7	1	1"	Schedule 80 Threaded	Milwaukee 510T Check Valve	
8	1	1"	Schedule 80 Threaded	Apollo 72-100 Ball Valve	
9	1	1"	Schedule 80 Threaded	Pipe	8 15/16'
10	1	1"	Schedule 80 Threaded	90 Degree Short Radius Elbow	
11	1	1"	Schedule 80 Threaded	Pipe	3 7/8'
12	1	1-1/2"	Schedule 80 Threaded	Coupling	
13	1	1-1/2"	Schedule 80 Threaded	Pipe	3'
14	1	1-1/2"	Schedule 80 Threaded	Expansion Joint	
15	1	1-1/2"	Schedule 80 Threaded	Pipe	4'
16	1	1-1/2"	Schedule 80 Threaded	Union	
17	1	1-1/2"	Schedule 80 Threaded	Pipe	9 3/4'
18	1	1-1/2"	Schedule 80 Threaded	90 Degree Short Radius Elbow	

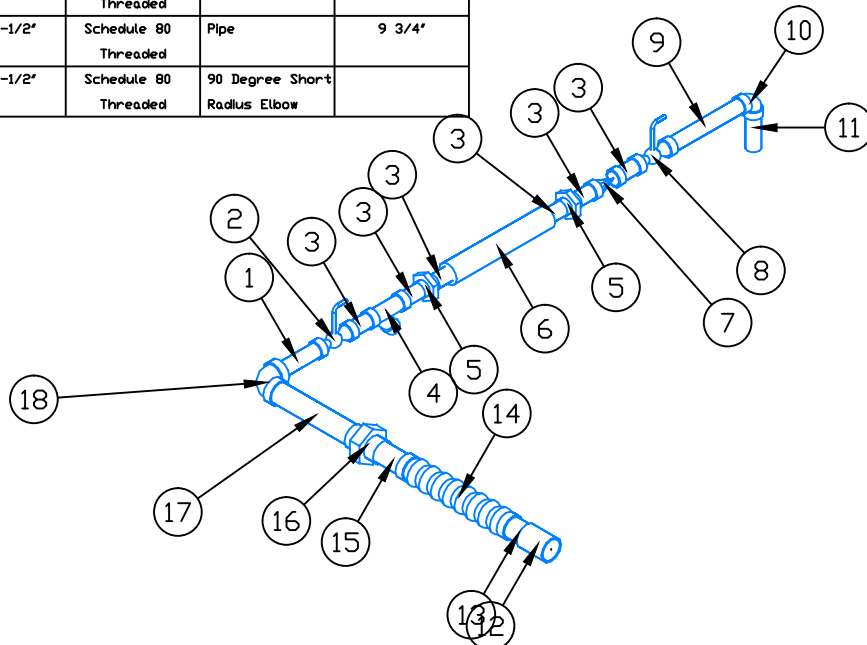

REVISIONS				
ZONE	REV	DESCRIPTION	DATE	APPROVED

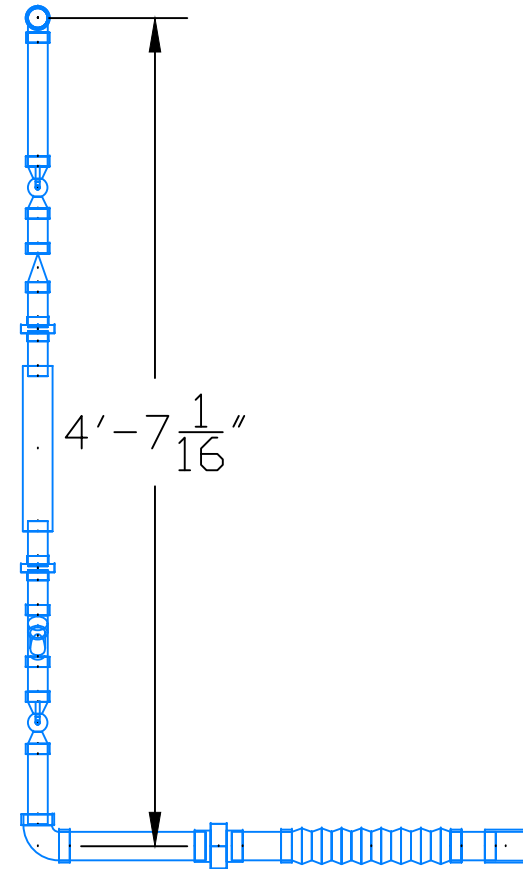

SERVICE	SHOP FABRICATE	X	STEAM,ELECT.TRACE	
HPC	FIELD FABRICATE		INSULATE	
DELGROSSD	BOILER CODE		X RAY	
	HEAVY WALL		STRESS RELIEF	
	ALLOY		COLOUR CODE	
REFERENCE DWG.	Intrepid i Design, LLC. 503 North Twelfth Ave. Altoona, PA. 16601 Phone: (814) 941-4570 Fax: (814) 946-9776			
MAP-3	Coordination Drawings			
	Job No	Drawing Name		Rev
	DELG17	GF-HPC-23		
DATE: 5/25/17	SIZE	SPEC		

Tag	Qty	Size	Sch/Conn	Description	Length
1	1	1"	Schedule 80 Threaded	Pipe	6'
2	1	1"	Schedule 80 Threaded	Apollo 72-100 Ball Valve	
3	6	1"	Schedule 80 Threaded	Pipe	6x3"
4	1	1"	Schedule 80 Threaded	Wye Strainer	
5	2	1"	Schedule 80 Threaded	Union	
6	1	1"	Schedule 80 Threaded	Steam Trap	
7	1	1"	Schedule 80 Threaded	Milwaukee 510T Check Valve	
8	1	1"	Schedule 80 Threaded	Apollo 72-100 Ball Valve	
9	1	1"	Schedule 80 Threaded	Pipe	1'-5 3/16"
10	1	1"	Schedule 80 Threaded	90 Degree Short Radius Elbow	
11	1	1"	Schedule 80 Threaded	Pipe	4'
12	1	1-1/2"	Schedule 80 Threaded	Coupling	
13	1	1-1/2"	Schedule 80 Threaded	Pipe	3'
14	1	1-1/2"	Schedule 80 Threaded	Expansion Joint	
15	1	1-1/2"	Schedule 80 Threaded	Pipe	4'
16	1	1-1/2"	Schedule 80 Threaded	Union	
17	1	1-1/2"	Schedule 80 Threaded	Pipe	6 3/4"
18	1	1-1/2"	Schedule 80 Threaded	90 Degree Short Radius Elbow	

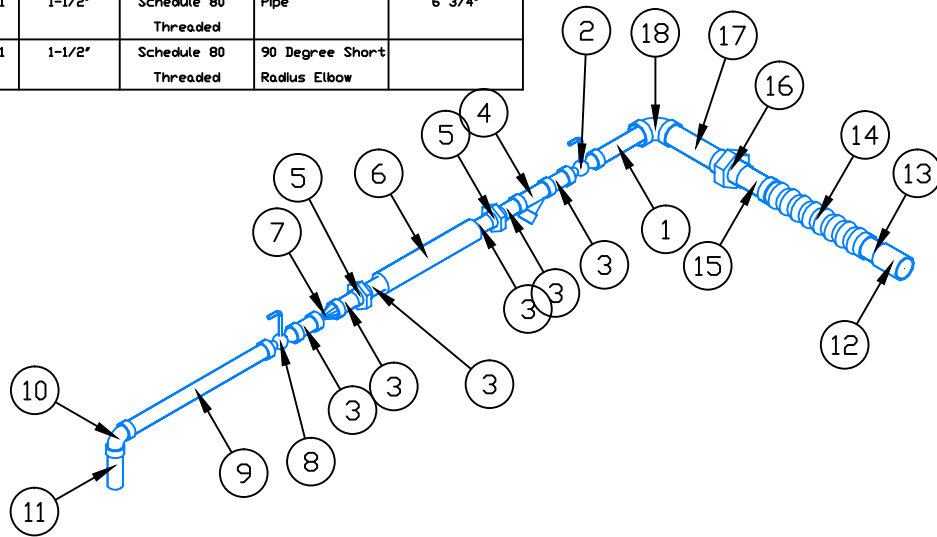

REVISIONS				
ZONE	REV	DESCRIPTION	DATE	APPROVED

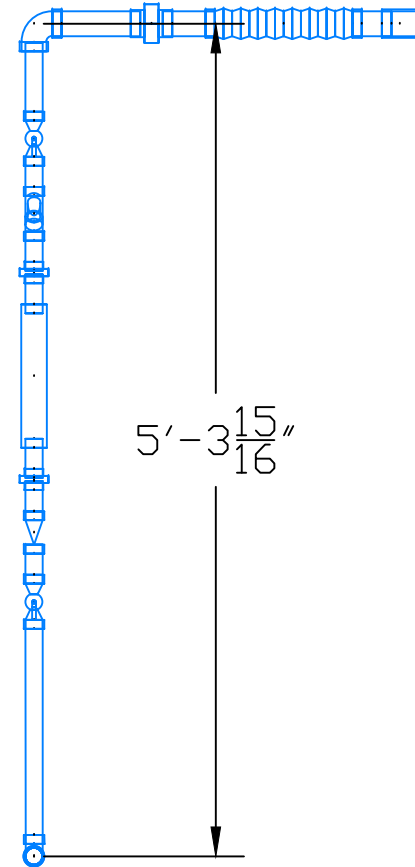

SERVICE	SHOP FABRICATE	X	STEAM,ELECT.TRACE	
HPC	FIELD FABRICATE		INSULATE	
DELGROSSD	BOILER CODE		X RAY	
	HEAVY WALL		STRESS RELIEF	
	ALLOY		COLOUR CODE	
REFERENCE DWG.	Intrepid i Design, LLC. 503 North Twelfth Ave. Altoona, PA. 16601 Phone: (814) 941-4570 Fax: (814) 946-9776			
MAP-3	Job No	Drawing Name		Rev
	DELG17	GF-HPC-24		
DATE: 5/25/17	SIZE	SPEC		

Tag	Qty	Size	Sch/Conn	Description	Length
1	1	1"	Schedule 80 Threaded	Pipe	6'
2	1	1"	Schedule 80 Threaded	Apollo 72-100 Ball Valve	
3	6	1"	Schedule 80 Threaded	Pipe	6x3'
4	1	1"	Schedule 80 Threaded	Wye Strainer	
5	2	1"	Schedule 80 Threaded	Union	
6	1	1"	Schedule 80 Threaded	Steam Trap	
7	1	1"	Schedule 80 Threaded	Milwaukee 510T Check Valve	
8	1	1"	Schedule 80 Threaded	Apollo 72-100 Ball Valve	
9	1	1"	Schedule 80 Threaded	Pipe	1'-9 1/4'
10	1	1"	Schedule 80 Threaded	90 Degree Short Radius Elbow	
11	1	1"	Schedule 80 Threaded	Pipe	3 7/8'
12	1	1-1/2"	Schedule 80 Threaded	Coupling	
13	1	1-1/2"	Schedule 80 Threaded	Pipe	3'
14	1	1-1/2"	Schedule 80 Threaded	Expansion Joint	
15	1	1-1/2"	Schedule 80 Threaded	Pipe	2 1/2'
16	1	1-1/2"	Schedule 80 Threaded	Union	
17	1	1-1/2"	Schedule 80 Threaded	Pipe	3 1/4'
18	1	1-1/2"	Schedule 80 Threaded	90 Degree Short Radius Elbow	

REVISIONS				
ZONE	REV	DESCRIPTION	DATE	APPROVED

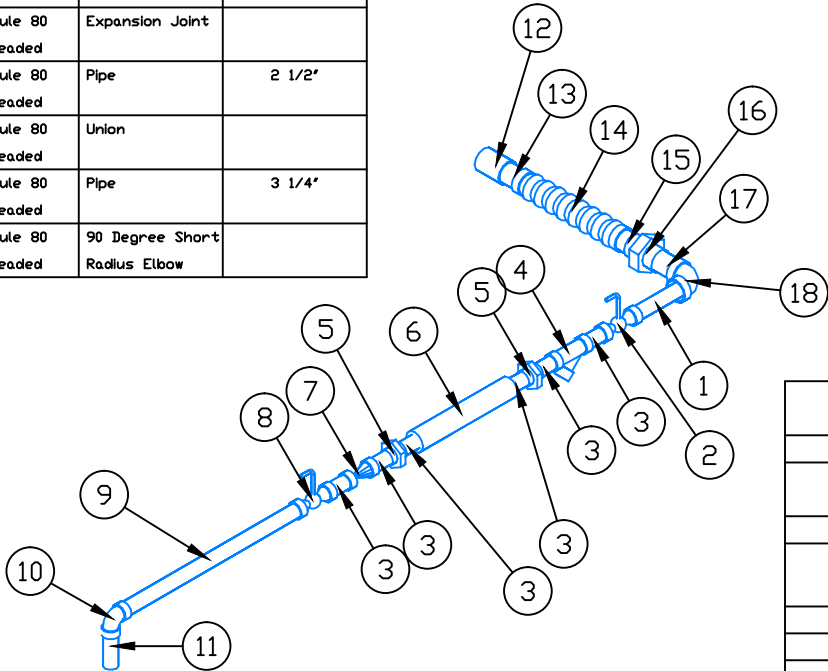
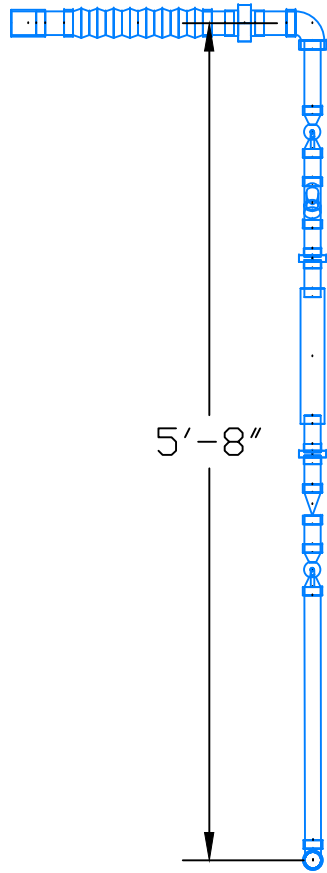

SERVICE	SHOP FABRICATE	X	STEAM,ELECT.TRACE	
HPC	FIELD FABRICATE		INSULATE	
DELGROSSD	BOILER CODE		X RAY	
	HEAVY WALL		STRESS RELIEF	
	ALLOY		COLOUR CODE	
REFERENCE DWG.	Intrepid  Design, LLC. 503 North Twelfth Ave. Altoona, PA. 16601 Phone: (814) 941-4570 Fax: (814) 946-9776			
MAP-3	Coordination Drawings			
	Job No	Drawing Name		Rev
	DELG17	GF-HPC-25		
DATE: 5/25/17	SIZE	SPEC		

Tag	Qty	Size	Sch/Conn	Description	Length
1	1	3/4"	Schedule 80 Threaded	Pipe	4'
2	1	3/4"	Schedule 80 Threaded	Apollo 72-100 Ball Valve	
3	6	3/4"	Schedule 80 Threaded	Pipe	6x3'
4	1	3/4"	Schedule 80 Threaded	Wye Strainer	
5	2	3/4"	Schedule 80 Threaded	Union	
6	1	3/4"	Schedule 80 Threaded	Steam Trap	
7	1	3/4"	Schedule 80 Threaded	Milwaukee 510T Check Valve	
8	1	3/4"	Schedule 80 Threaded	Apollo 72-100 Ball Valve	
9	1	3/4"	Schedule 80 Threaded	Pipe	1'-10 11/16"
10	1	3/4"	Schedule 80 Threaded	90 Degree Short Radius Elbow	
11	1	3/4"	Schedule 80 Threaded	Pipe	1'-0 7/8"

REVISIONS				
ZONE	REV	DESCRIPTION	DATE	APPROVED

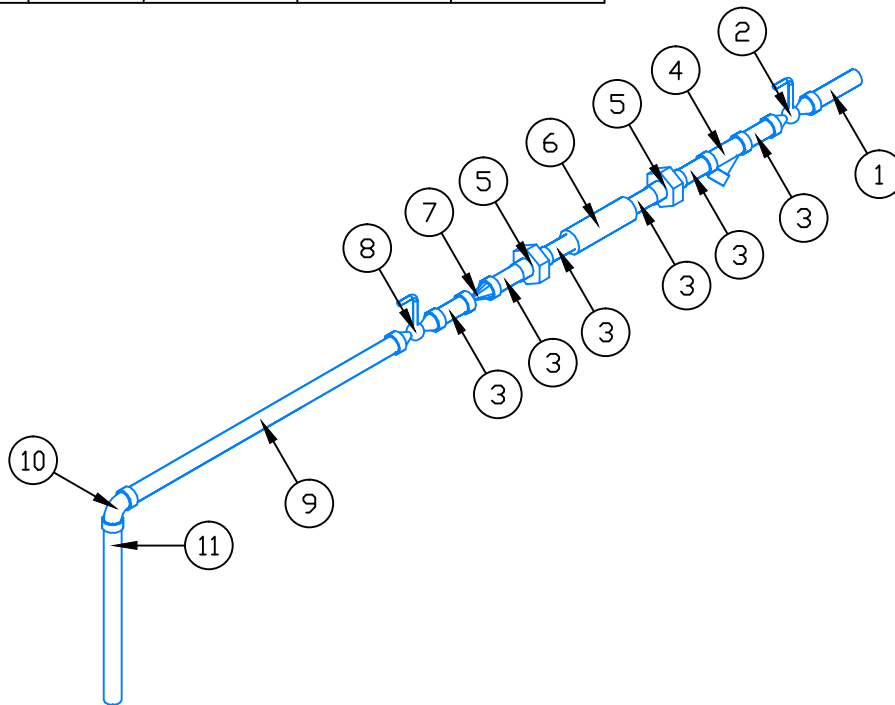
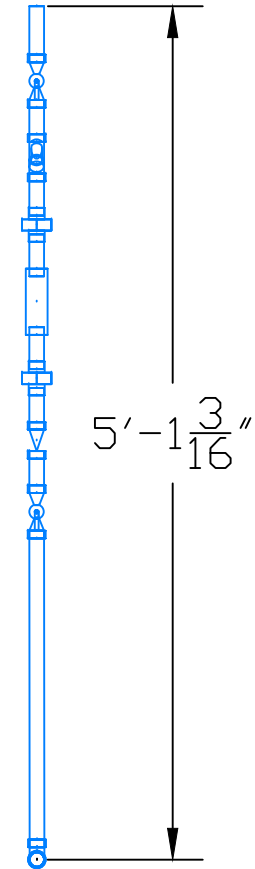

SERVICE	SHOP FABRICATE	X	STEAM,ELECT.TRACE	
HPC	FIELD FABRICATE		INSULATE	
DELGROSSO	BOILER CODE		X RAY	
	HEAVY WALL		STRESS RELIEF	
	ALLOY		COLOUR CODE	
REFERENCE DWG.	Intrepid i Design, LLC. 503 North Twelfth Ave. Altoona, PA. 16601 Phone: (814) 941-4570 Fax: (814) 946-9776			
MAP-3	Job No	Drawing Name		Rev
	DELG17	GF-HPC-26		
DATE: 5/25/17	SIZE	SPEC		

Tag	Qty	Size	Sch/Conn	Description	Length
1	1	3/4"	Schedule 80 Threaded	Pipe	1'
2	1	3/4"	Schedule 80 Threaded	Apollo 72-100 Ball Valve	
3	6	3/4"	Schedule 80 Threaded	Pipe	6x3'
4	1	3/4"	Schedule 80 Threaded	Wye Strainer	
5	2	3/4"	Schedule 80 Threaded	Union	
6	1	3/4"	Schedule 80 Threaded	Steam Trap	
7	1	3/4"	Schedule 80 Threaded	Milwaukee 510T Check Valve	
8	1	3/4"	Schedule 80 Threaded	Apollo 72-100 Ball Valve	
9	1	3/4"	Schedule 80 Threaded	Pipe	9 7/8'
10	3	3/4"	Schedule 80 Threaded	90 Degree Short Radius Elbow	
11	1	3/4"	Schedule 80 Threaded	Pipe	2'-5 5/8'
12	1	3/4"	Schedule 80 Threaded	Pipe	4 3/8'
13	1	3/4"	Schedule 80 Threaded	Pipe	3 3/4'

REVISIONS				
ZONE	REV	DESCRIPTION	DATE	APPROVED

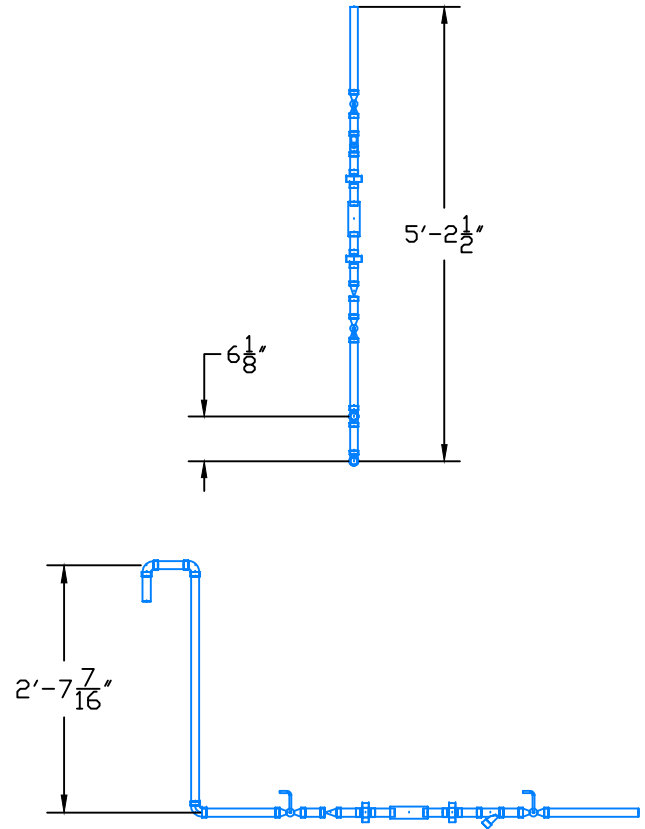
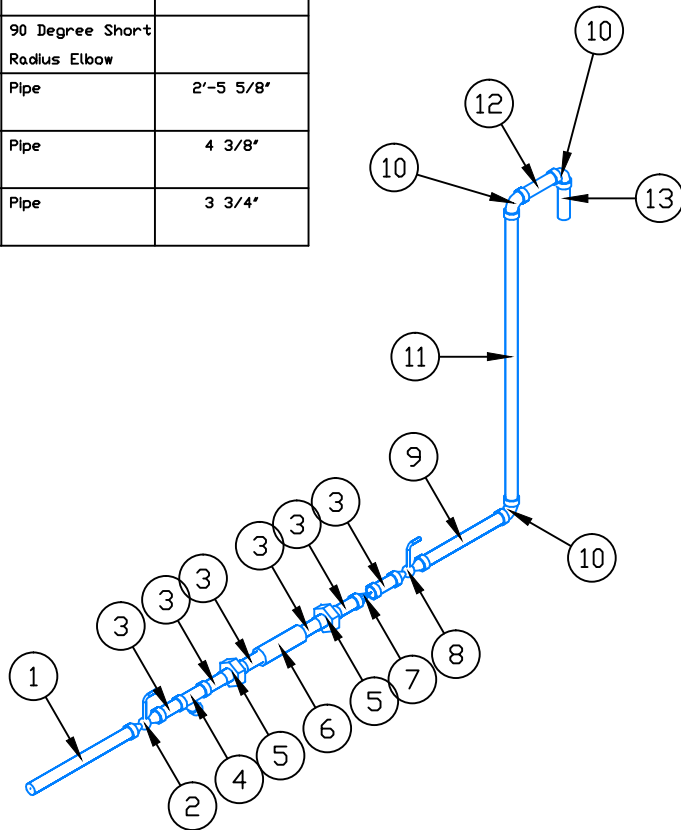

SERVICE	SHOP FABRICATE	X	STEAM,ELECT.TRACE	
HPC	FIELD FABRICATE		INSULATE	
DELGROSSD	BOILER CODE		X RAY	
REFERENCE DWG.	HEAVY WALL		STRESS RELIEF	
MAP-3	ALLOY		COLOUR CODE	
	Intrepid  Design, LLC. 503 North Twelfth Ave. Altoona, PA. 16601 Phone: (814) 941-4570 Fax: (814) 946-9776			
	Job No	Drawing Name		Rev
	DELG17	GF-HPC-27		
DATE: 5/25/17	SIZE	SPEC		

Tag	Qty	Size	Sch/Conn	Description	Length
1	1	1"	Schedule 80 Threaded	Pipe	4'
2	1	1"	Schedule 80 Threaded	Apollo 72-100 Ball Valve	
3	6	1"	Schedule 80 Threaded	Pipe	6x3'
4	1	1"	Schedule 80 Threaded	Wye Strainer	
5	2	1"	Schedule 80 Threaded	Union	
6	1	1"	Schedule 80 Threaded	Steam Trap	
7	1	1"	Schedule 80 Threaded	Milwaukee 510T Check Valve	
8	1	1"	Schedule 80 Threaded	Apollo 72-100 Ball Valve	
9	2	1"	Schedule 80 Threaded	Pipe	2x3 9/16'
10	3	1"	Schedule 80 Threaded	90 Degree Short Radius Elbow	
11	1	1"	Schedule 80 Threaded	Pipe	2'-5 9/16'
12	1	1"	Schedule 80 Threaded	Pipe	4 1/4'
13	1	1-1/2"	Schedule 80 Threaded	Tee	
14	1	1-1/2"	Schedule 80 Threaded	Pipe	3'
15	1	1-1/2"	Schedule 80 Threaded	Expansion Joint	
16	1	1-1/2"	Schedule 80 Threaded	End Cap	
17	1	1-1/2"	Schedule 80 Threaded	Pipe	10'

REVISIONS				
ZONE	REV	DESCRIPTION	DATE	APPROVED

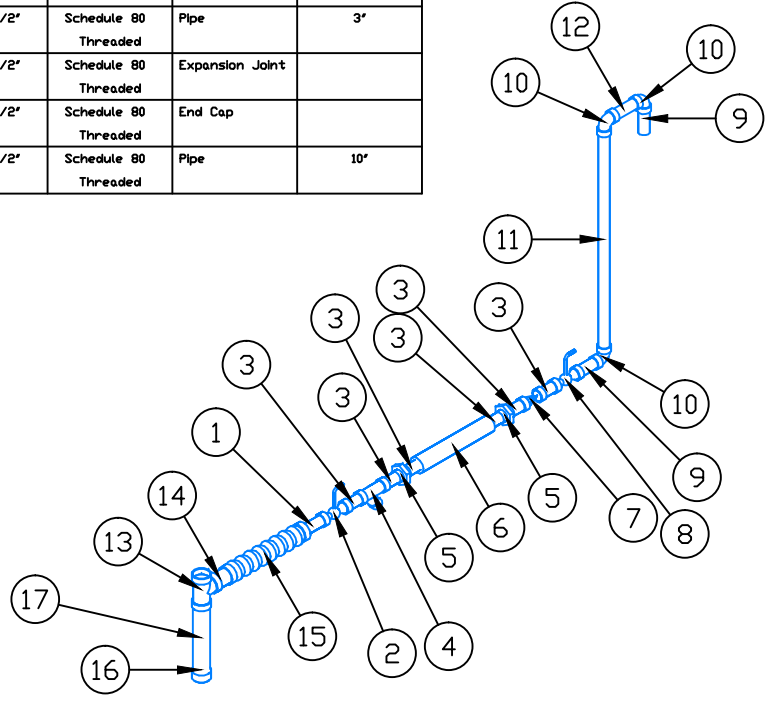
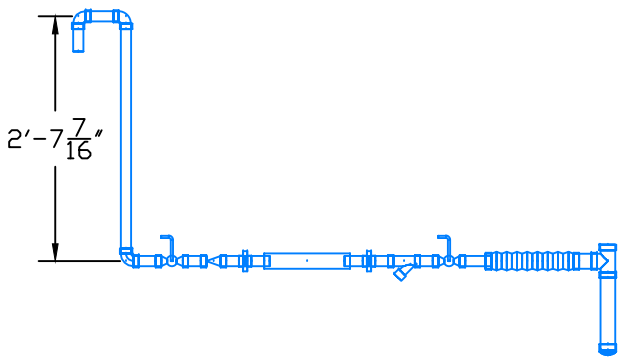
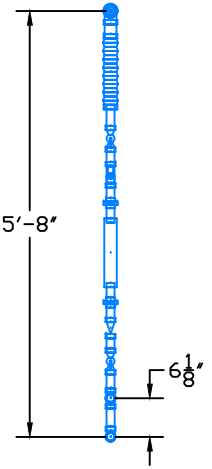

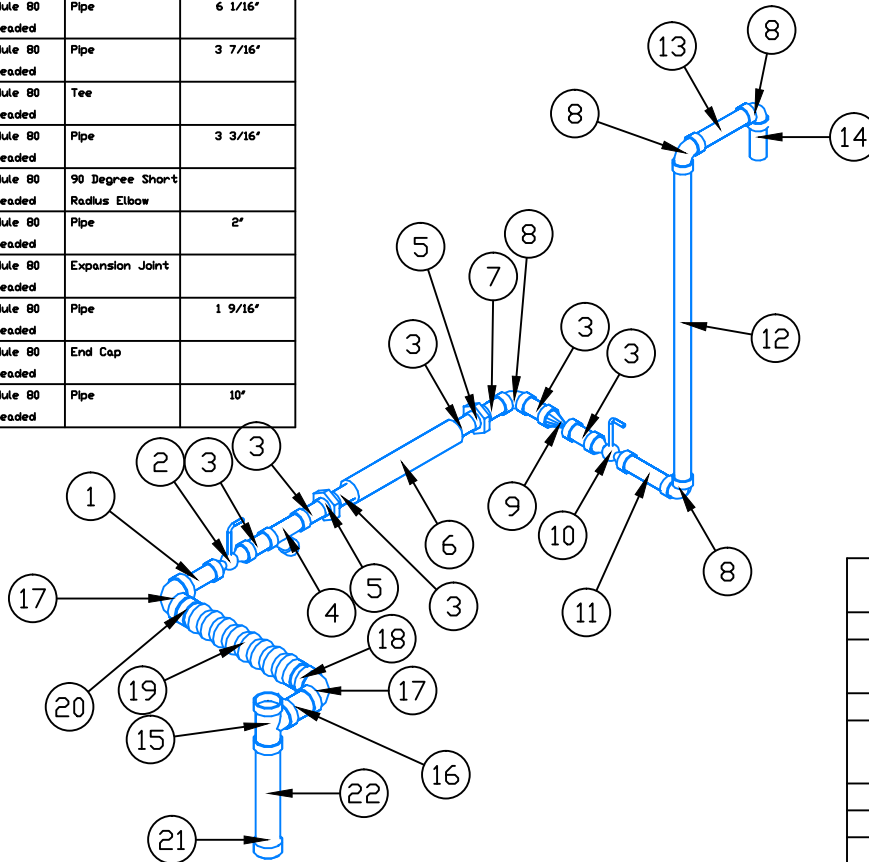

SERVICE	SHOP FABRICATE	X	STEAM,ELECT.TRACE	
HPC	FIELD FABRICATE		INSULATE	
DELGROSSD	BOILER CODE		X RAY	
REFERENCE DWG.	HEAVY WALL		STRESS RELIEF	
MAP-3	ALLOY		COLOUR CODE	
	Intrepid i Design, LLC. 503 North Twelfth Ave. Altoona, PA. 16601 Phone: (814) 941-4570 Fax: (814) 946-9776			
	Job No	Drawing Name		Rev
	DELG17	GF-HPC-28		
DATE: 5/25/17	SIZE	SPEC		

Tag	Qty	Size	Sch/Conn	Description	Length
1	1	1"	Schedule 80 Threaded	Pipe	4'
2	1	1"	Schedule 80 Threaded	Apollo 72-100 Ball Valve	
3	6	1"	Schedule 80 Threaded	Pipe	6x3'
4	1	1"	Schedule 80 Threaded	Wye Strainer	
5	2	1"	Schedule 80 Threaded	Union	
6	1	1"	Schedule 80 Threaded	Steam Trap	
7	1	1"	Schedule 80 Threaded	Pipe	2 15/16"
8	4	1"	Schedule 80 Threaded	90 Degree Short Radius Elbow	
9	1	1"	Schedule 80 Threaded	Milwaukee 510T Check Valve	
10	1	1"	Schedule 80 Threaded	Apollo 72-100 Ball Valve	
11	1	1"	Schedule 80 Threaded	Pipe	5 1/4"
12	1	1"	Schedule 80 Threaded	Pipe	2'-5 9/16"
13	1	1"	Schedule 80 Threaded	Pipe	6 1/16"
14	1	1"	Schedule 80 Threaded	Pipe	3 7/16"
15	1	1-1/2"	Schedule 80 Threaded	Tee	
16	1	1-1/2"	Schedule 80 Threaded	Pipe	3 3/16"
17	2	1-1/2"	Schedule 80 Threaded	90 Degree Short Radius Elbow	
18	1	1-1/2"	Schedule 80 Threaded	Pipe	2"
19	1	1-1/2"	Schedule 80 Threaded	Expansion Joint	
20	1	1-1/2"	Schedule 80 Threaded	Pipe	1 9/16"
21	1	1-1/2"	Schedule 80 Threaded	End Cap	
22	1	1-1/2"	Schedule 80 Threaded	Pipe	10"

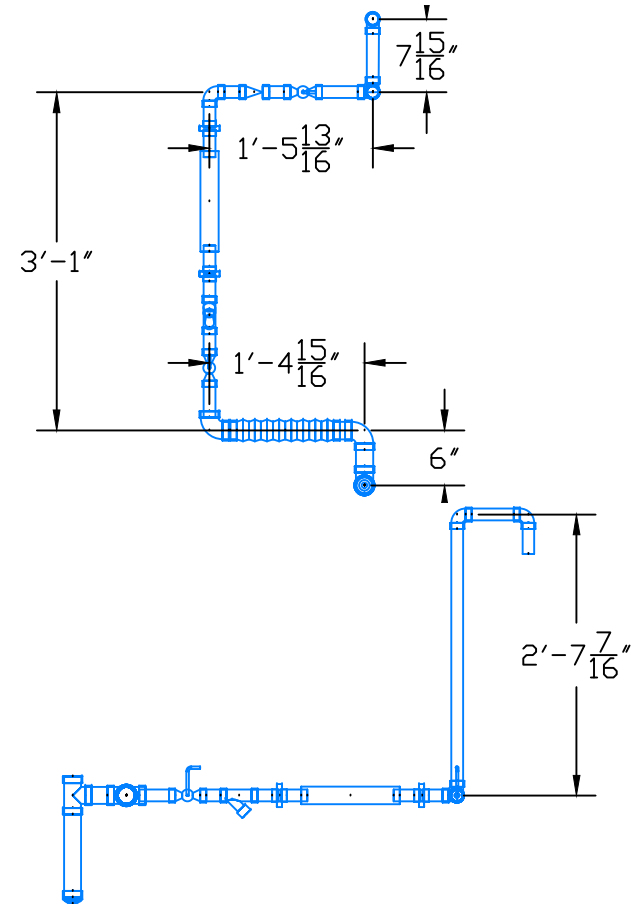

REVISIONS				
ZONE	REV	DESCRIPTION	DATE	APPROVED



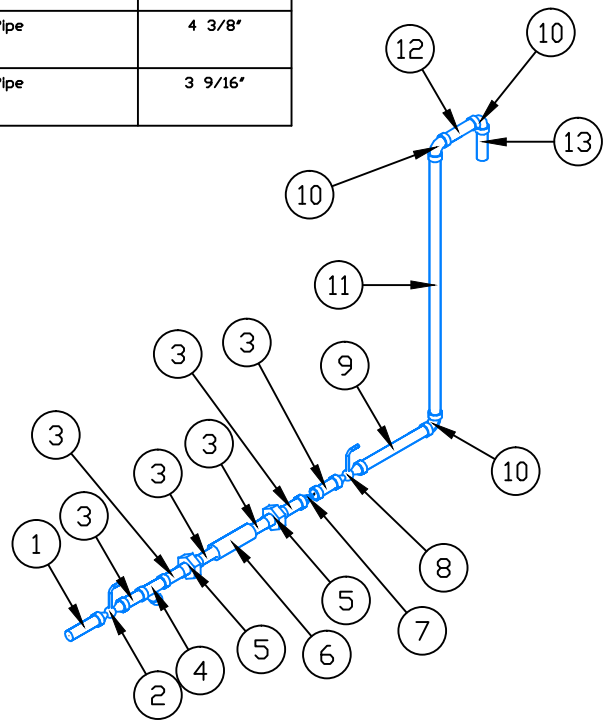

SERVICE	SHOP FABRICATE	X	STEAM,ELECT.TRACE	
HPC	FIELD FABRICATE		INSULATE	
DELGROSSO	BOILER CODE		X RAY	
REFERENCE DWG.	HEAVY WALL		STRESS RELIEF	
MAP-3	ALLOY		COLOUR CODE	
	Intrepid  Design, LLC. 503 North Twelfth Ave. Altoona, PA. 16601 Phone: (814) 941-4570 Fax: (814) 946-9776			
	Job No	Drawing Name		Rev
	DELG17	GF-HPC-29		
DATE: 5/25/17	SIZE	SPEC		

Tag	Qty	Size	Sch/Conn	Description	Length						
1	1	3/4"	Schedule 80 Threaded	Pipe	4'						
2	1	3/4"	Schedule 80 Threaded	Apollo 72-100 Ball Valve							
3	6	3/4"	Schedule 80 Threaded	Pipe	6x3'						
4	1	3/4"	Schedule 80 Threaded	Wye Strainer							
5	2	3/4"	Schedule 80 Threaded	Union							
6	1	3/4"	Schedule 80 Threaded	Steam Trap							
7	1	3/4"	Schedule 80 Threaded	Milwaukee 510T Check Valve							
8	1	3/4"	Schedule 80 Threaded	Apollo 72-100 Ball Valve							
9	1	3/4"	Schedule 80 Threaded	Pipe	9 1/8'						
10	3	3/4"	Schedule 80 Threaded	90 Degree Short Radius Elbow							
11	1	3/4"	Schedule 80 Threaded	Pipe	2'-5 5/8'						
12	1	3/4"	Schedule 80 Threaded	Pipe	4 3/8'	13	1	3/4"	Schedule 80 Threaded	Pipe	3 9/16'
13	1	3/4"	Schedule 80 Threaded	Pipe	3 9/16'						

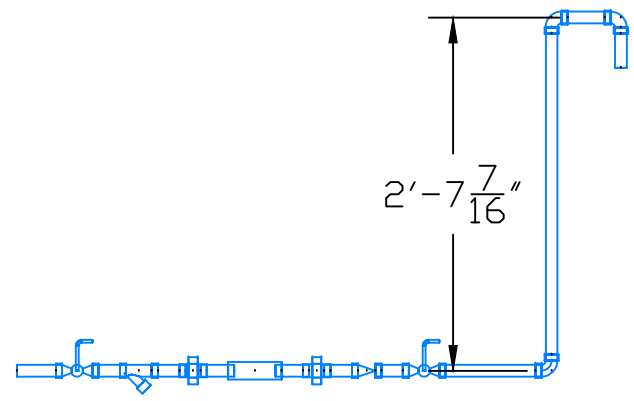
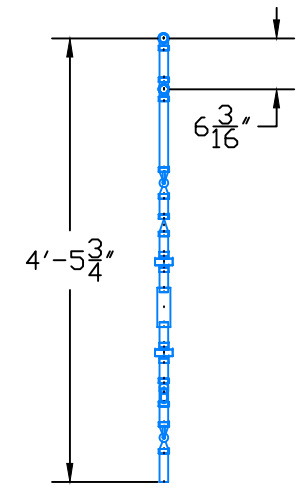

REVISIONS				
ZONE	REV	DESCRIPTION	DATE	APPROVED



SERVICE	SHOP FABRICATE	X	STEAM,ELECT.TRACE	
HPC	FIELD FABRICATE		INSULATE	
DELGROSSO	BOILER CODE		X RAY	
REFERENCE DWG.	HEAVY WALL		STRESS RELIEF	
MAP-3	ALLOY		COLOUR CODE	
	Intrepid  Design, LLC. 503 North Twelfth Ave. Altoona, PA. 16601 Coordination Drawings Phone: (814) 941-4570 Fax: (814) 946-9776			
	Job No	Drawing Name		Rev
	DELG17	GF-HPC-30		
DATE: 5/25/17	SIZE	SPEC		

Tag	Qty	Size	Sch/Conn	Description	Length
1	7	3/4"	Schedule 80 Threaded	Pipe	7x3'
2	1	3/4"	Schedule 80 Threaded	Apollo 72-100 Ball Valve	
3	1	3/4"	Schedule 80 Threaded	Wye Strainer	
4	1	3/4"	Schedule 80 Threaded	Pipe	1'-4 1/2"
5	2	3/4"	Schedule 80 Threaded	90 Degree Short Radius Elbow	
6	2	3/4"	Schedule 80 Threaded	Union	
7	1	3/4"	Schedule 80 Threaded	Steam Trap	
8	1	3/4"	Schedule 80 Threaded	Milwaukee 510T Check Valve	
9	1	3/4"	Schedule 80 Threaded	Apollo 72-100 Ball Valve	
10	1	3/4"	Schedule 80 Threaded	Pipe	2'-8 9/16"
11	1	3/4"	Schedule 80 Threaded	Pipe	1'-0 15/16"

REVISIONS				
ZONE	REV	DESCRIPTION	DATE	APPROVED

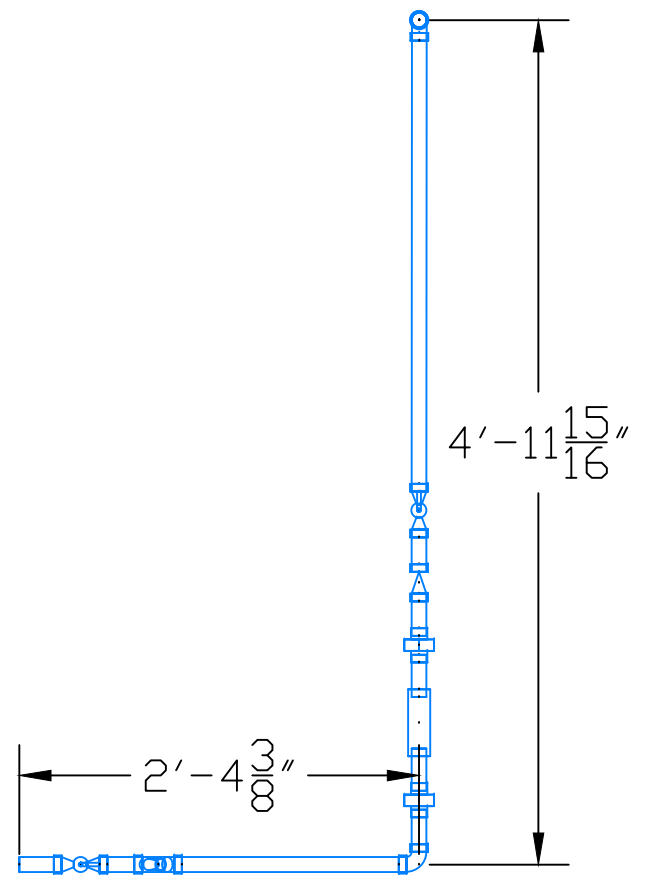
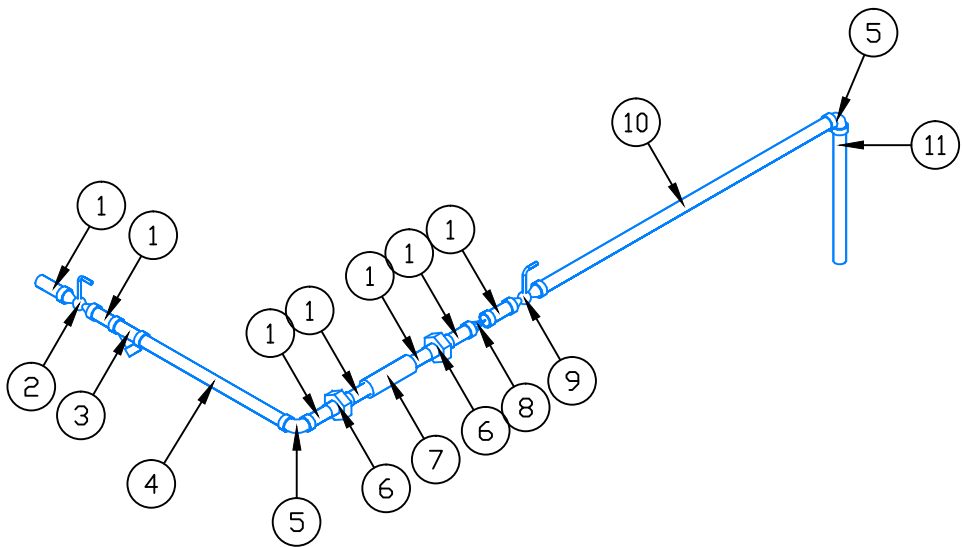

SERVICE	SHOP FABRICATE	X	STEAM,ELECT.TRACE	
HPC	FIELD FABRICATE		INSULATE	
DELGROSSD	BOILER CODE		X RAY	
	HEAVY WALL		STRESS RELIEF	
	ALLOY		COLOUR CODE	
REFERENCE DWG.	Intrepid i Design, LLC. 503 North Twelfth Ave. Altoona, PA. 16601 Phone: (814) 941-4570 Fax: (814) 946-9776			
MAP-3	Coordination Drawings			
	Job No	Drawing Name		Rev
	DELG17	GF-HPC-31		
DATE: 5/25/17	SIZE	SPEC		

Tag	Qty	Size	Sch/Conn	Description	Length
1	1	1"	Schedule 80 Threaded	Pipe	3 1/4"
2	1	1"	Schedule 80 Threaded	Apollo 72-100 Ball Valve	
3	6	1"	Schedule 80 Threaded	Pipe	6x3'
4	1	1"	Schedule 80 Threaded	Vye Strainer	
5	2	1"	Schedule 80 Threaded	Union	
6	1	1"	Schedule 80 Threaded	Steam Trap	
7	1	1"	Schedule 80 Threaded	Milwaukee 510T Check Valve	
8	1	1"	Schedule 80 Threaded	Apollo 72-100 Ball Valve	
9	1	1"	Schedule 80 Threaded	Pipe	2 3/4"
10	1	1"	Schedule 80 Threaded	90 Degree Short Radius Elbow	
11	1	1"	Schedule 80 Threaded	Pipe	3 11/16"
12	1	1-1/2"	Schedule 80 Threaded	Coupling	
13	1	1-1/2"	Schedule 80 Threaded	Pipe	1 13/16"
14	1	1-1/2"	Schedule 80 Threaded	Expansion Joint	
15	1	1-1/2"	Schedule 80 Threaded	Pipe	1 9/16"
16	1	1-1/2"	Schedule 80 Threaded	90 Degree Short Radius Elbow	
17	1	1-1/2"	Schedule 80 Threaded	Pipe	2 1/2"
18	1	1-1/2"	Schedule 80 Threaded	Union	

REVISIONS				
ZONE	REV	DESCRIPTION	DATE	APPROVED

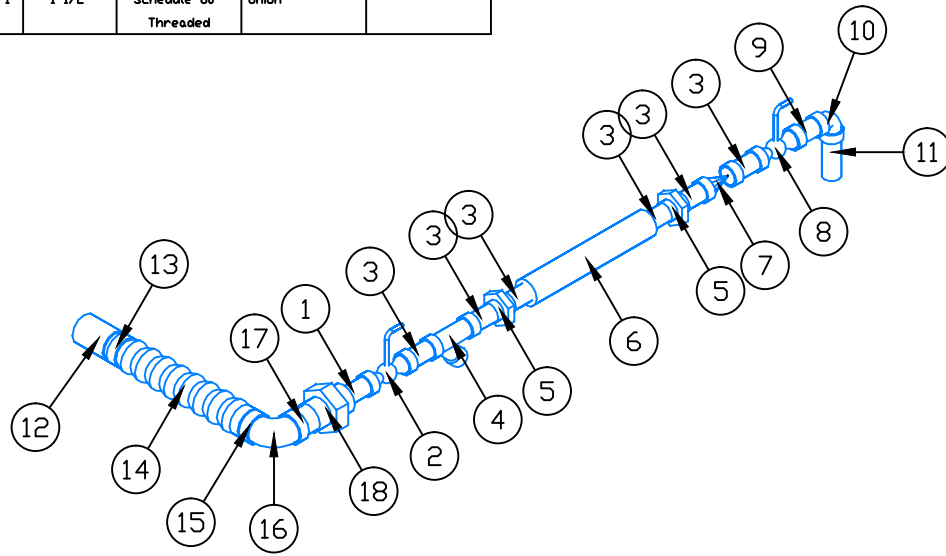
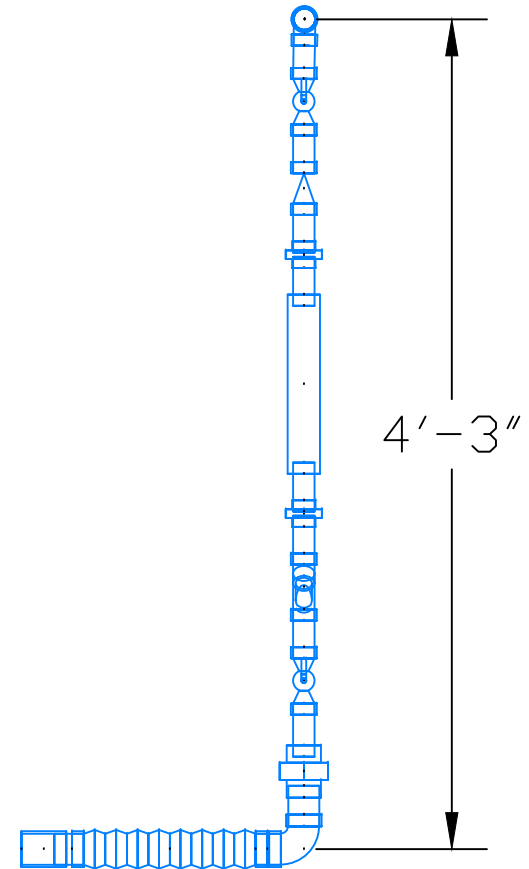

SERVICE	SHOP FABRICATE	X	STEAM,ELECT.TRACE	
HPC	FIELD FABRICATE		INSULATE	
DELGROSSD	BOILER CODE		X RAY	
	HEAVY WALL		STRESS RELIEF	
	ALLOY		COLOUR CODE	
REFERENCE DWG.	Intrepid  Design, LLC. 503 North Twelfth Ave. Altoona, PA. 16601 Phone: (814) 941-4570 Fax: (814) 946-9776			
MAP-3	Job No	Drawing Name		Rev
	DELG17	GF-HPC-32		
DATE: 5/25/17	SIZE	SPEC		

Tag	Qty	Size	Sch/Conn	Description	Length
1	2	1"	Schedule 80 Threaded	Pipe	2x4'
2	1	1"	Schedule 80 Threaded	Apollo 72-100 Ball Valve	
3	5	1"	Schedule 80 Threaded	Pipe	5x3'
4	1	1"	Schedule 80 Threaded	Vye Strainer	
5	2	1"	Schedule 80 Threaded	Union	
6	1	1"	Schedule 80 Threaded	Steam Trap	
7	1	1"	Schedule 80 Threaded	Pipe	2 15/16'
8	4	1"	Schedule 80 Threaded	90 Degree Short Radius Elbow	
9	1	1"	Schedule 80 Threaded	Milwaukee 510T Check Valve	
10	1	1"	Schedule 80 Threaded	Apollo 72-100 Ball Valve	
11	1	1"	Schedule 80 Threaded	Pipe	1'-1 11/16"
12	1	1"	Schedule 80 Threaded	Pipe	2'-5 9/16"
13	1	1"	Schedule 80 Threaded	Pipe	9 3/16"
14	1	1"	Schedule 80 Threaded	Pipe	3 1/2"
15	1	1-1/2"	Schedule 80 Threaded	Tee	
16	1	1-1/2"	Schedule 80 Threaded	Pipe	9 3/16"
17	2	1-1/2"	Schedule 80 Threaded	90 Degree Short Radius Elbow	
18	2	1-1/2"	Schedule 80 Threaded	Pipe	2x2'
19	1	1-1/2"	Schedule 80 Threaded	Expansion Joint	
20	1	1-1/2"	Schedule 80 Threaded	End Cap	
21	1	1-1/2"	Schedule 80 Threaded	Pipe	10'

REVISIONS				
ZONE	REV	DESCRIPTION	DATE	APPROVED

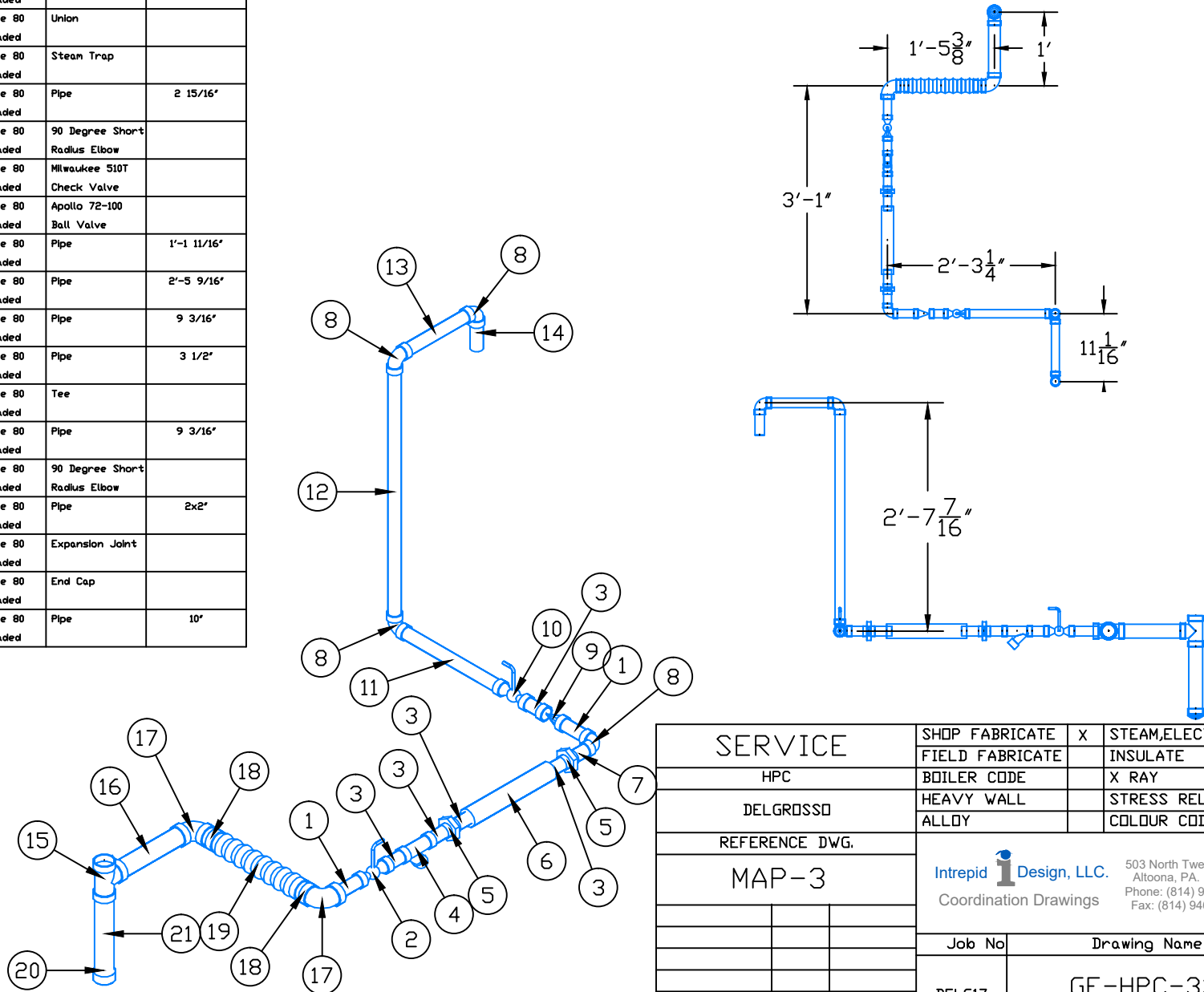

SERVICE	SHOP FABRICATE	X	STEAM,ELECT.TRACE	
HPC	FIELD FABRICATE		INSULATE	
DELGROSSD	HEAVY WALL		X RAY	
REFERENCE DWG.	ALLOY		COLOUR CODE	
MAP-3	Intrepid i Design, LLC. 503 North Twelfth Ave. Altoona, PA. 16601 Phone: (814) 941-4570 Fax: (814) 946-9776			
	Job No	Drawing Name		Rev
	DELG17	GF-HPC-33		
DATE: 5/25/17	SIZE	SPEC		

Tag	Qty	Size	Sch/Conn	Description	Length
1	1	3/4"	Schedule 80 Threaded	Pipe	4'
2	1	3/4"	Schedule 80 Threaded	Apollo 72-100 Ball Valve	
3	6	3/4"	Schedule 80 Threaded	Pipe	6x3'
4	1	3/4"	Schedule 80 Threaded	Wye Strainer	
5	2	3/4"	Schedule 80 Threaded	Union	
6	1	3/4"	Schedule 80 Threaded	Steam Trap	
7	1	3/4"	Schedule 80 Threaded	Milwaukee 510T Check Valve	
8	1	3/4"	Schedule 80 Threaded	Apollo 72-100 Ball Valve	
9	1	3/4"	Schedule 80 Threaded	Pipe	9 7/8'
10	4	3/4"	Schedule 80 Threaded	90 Degree Short Radius Elbow	
11	1	3/4"	Schedule 80 Threaded	Pipe	7 11/16'
12	1	3/4"	Schedule 80 Threaded	Pipe	2'-5 5/8"
13	1	3/4"	Schedule 80 Threaded	Pipe	4 3/8"
14	1	3/4"	Schedule 80 Threaded	Pipe	3 5/8"

REVISIONS				
ZONE	REV	DESCRIPTION	DATE	APPROVED

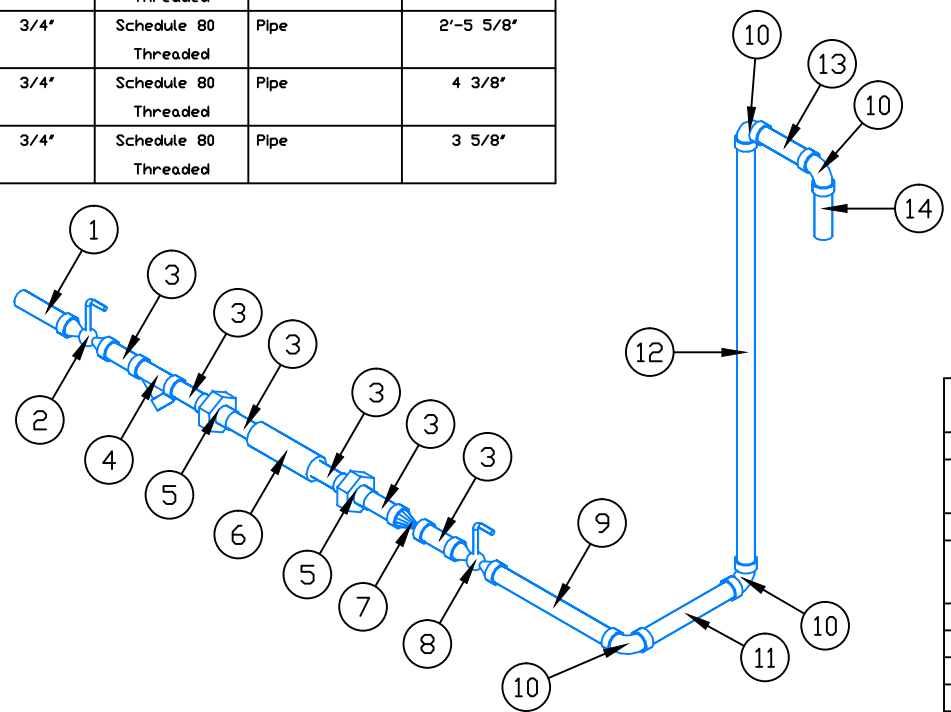
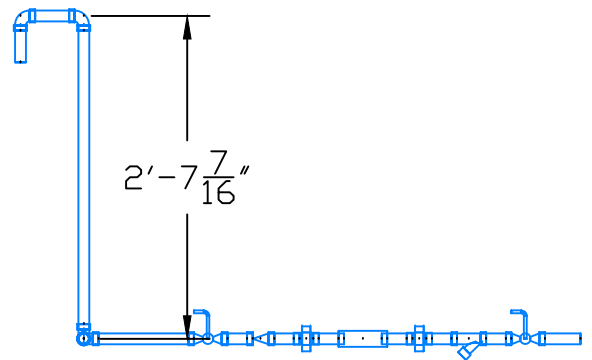
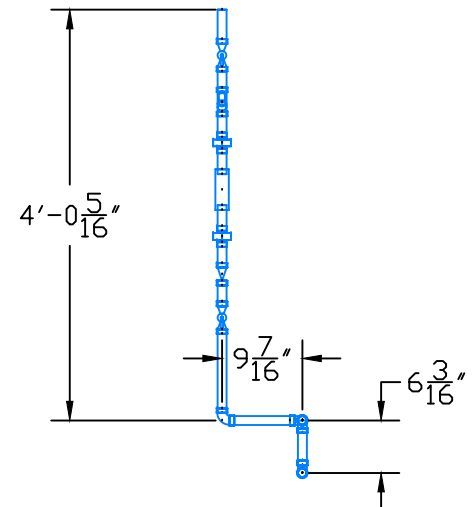

SERVICE	SHOP FABRICATE	X	STEAM,ELECT.TRACE	
HPC	FIELD FABRICATE		INSULATE	
DELGROSSD	BOILER CODE		X RAY	
REFERENCE DWG.	HEAVY WALL		STRESS RELIEF	
MAP-3	ALLOY		COLOUR CODE	
	Intrepid i Design, LLC. 503 North Twelfth Ave. Altoona, PA. 16601 Phone: (814) 941-4570 Fax: (814) 946-9776			
	Job No	Drawing Name		Rev
	DELG17	GF-HPC-34		
DATE: 5/25/17	SIZE	SPEC		

Tag	Qty	Size	Sch/Conn	Description	Length
1	1	1"	Schedule 80 Threaded	Pipe	4'
2	1	1"	Schedule 80 Threaded	Apollo 72-100 Ball Valve	
3	6	1"	Schedule 80 Threaded	Pipe	6x3"
4	1	1"	Schedule 80 Threaded	Wye Strainer	
5	2	1"	Schedule 80 Threaded	Union	
6	1	1"	Schedule 80 Threaded	Steam Trap	
7	1	1"	Schedule 80 Threaded	Milwaukee 510T Check Valve	
8	1	1"	Schedule 80 Threaded	Apollo 72-100 Ball Valve	
9	1	1"	Schedule 80 Threaded	Pipe	1'-3 1/4"
10	1	1"	Schedule 80 Threaded	90 Degree Short Radius Elbow	
11	1	1"	Schedule 80 Threaded	Pipe	3 3/4"
12	1	1-1/2"	Schedule 80 Threaded	Coupling	
13	1	1-1/2"	Schedule 80 Threaded	Pipe	4'
14	1	1-1/2"	Schedule 80 Threaded	Expansion Joint	
15	1	1-1/2"	Schedule 80 Threaded	Pipe	3'
16	1	1-1/2"	Schedule 80 Threaded	Union	
17	1	1-1/2"	Schedule 80 Threaded	Pipe	3 5/8"
18	1	1-1/2"	Schedule 80 Threaded	90 Degree Short Radius Elbow	

REVISIONS				
ZONE	REV	DESCRIPTION	DATE	APPROVED

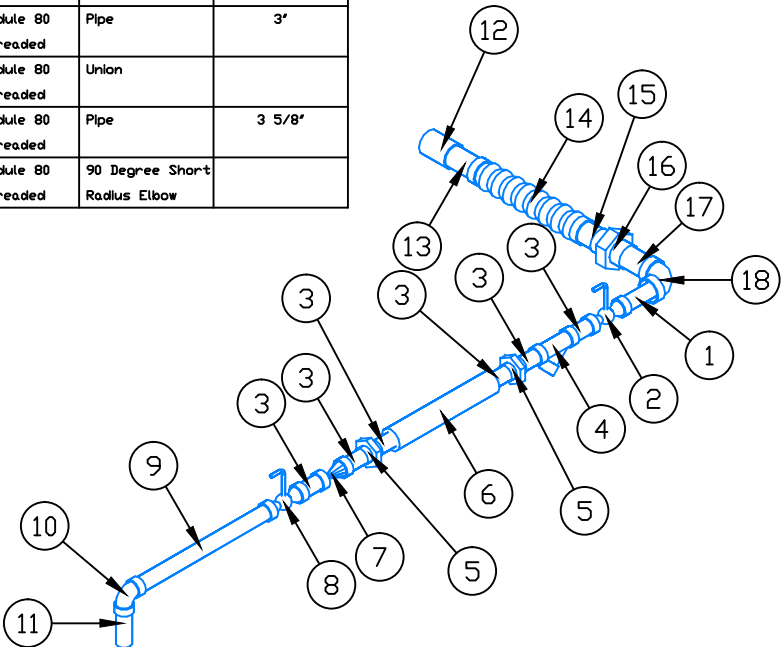
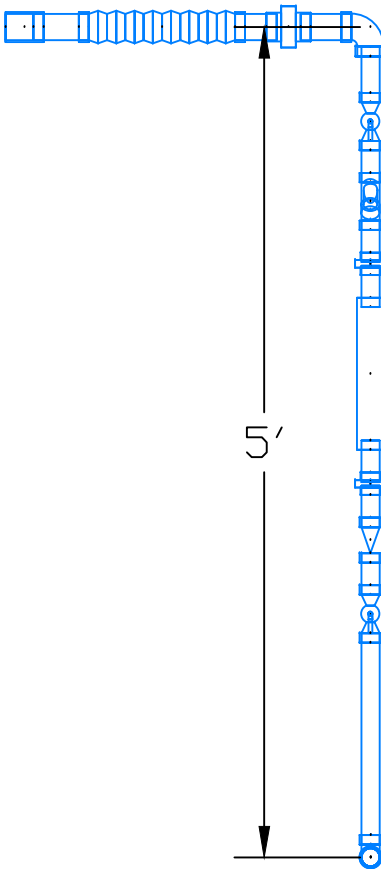

SERVICE	SHOP FABRICATE	X	STEAM,ELECT.TRACE	
HPC	FIELD FABRICATE		INSULATE	
DELGROSSD	BOILER CODE		X RAY	
REFERENCE DWG.	HEAVY WALL		STRESS RELIEF	
MAP-3	ALLOY		COLOUR CODE	
	Intrepid i Design, LLC. 503 North Twelfth Ave. Altoona, PA. 16601 Phone: (814) 941-4570 Fax: (814) 946-9776			
	Job No	Drawing Name		Rev
	DELG17	GF-HPC-35		
DATE: 5/25/17	SIZE	SPEC		

Tag	Qty	Size	Sch/Conn	Description	Length
1	1	3/4"	Schedule 80 Threaded	Pipe	4'
2	1	3/4"	Schedule 80 Threaded	Apollo 72-100 Ball Valve	
3	5	3/4"	Schedule 80 Threaded	Pipe	5x3'
4	1	3/4"	Schedule 80 Threaded	Wye Strainer	
5	1	3/4"	Schedule 80 Threaded	Pipe	2'-0 1/2"
6	2	3/4"	Schedule 80 Threaded	90 Degree Short Radius Elbow	
7	1	3/4"	Schedule 80 Threaded	Pipe	6'
8	2	3/4"	Schedule 80 Threaded	Union	
9	1	3/4"	Schedule 80 Threaded	Steam Trap	
10	1	3/4"	Schedule 80 Threaded	Milwaukee 510T Check Valve	
11	1	3/4"	Schedule 80 Threaded	Apollo 72-100 Ball Valve	
12	1	3/4"	Schedule 80 Threaded	Pipe	2'-1 13/16"
13	1	3/4"	Schedule 80 Threaded	Pipe	1'-0 15/16"

REVISIONS				
ZONE	REV	DESCRIPTION	DATE	APPROVED

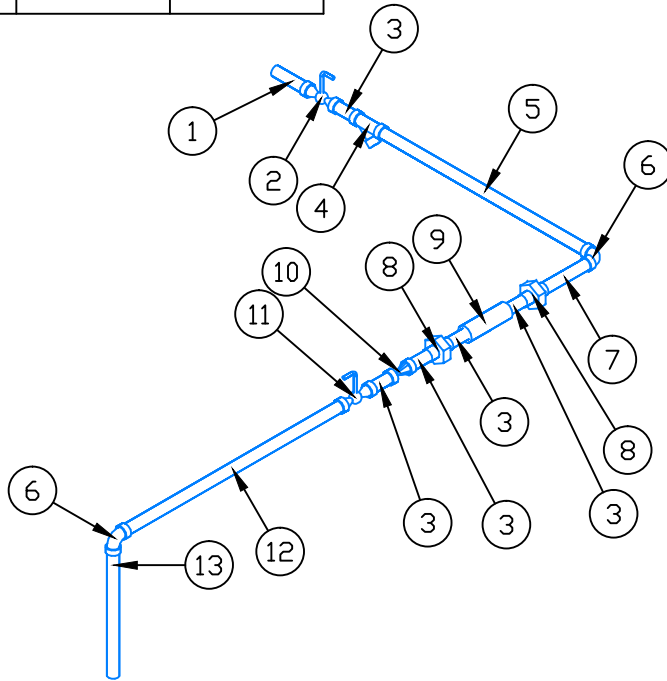
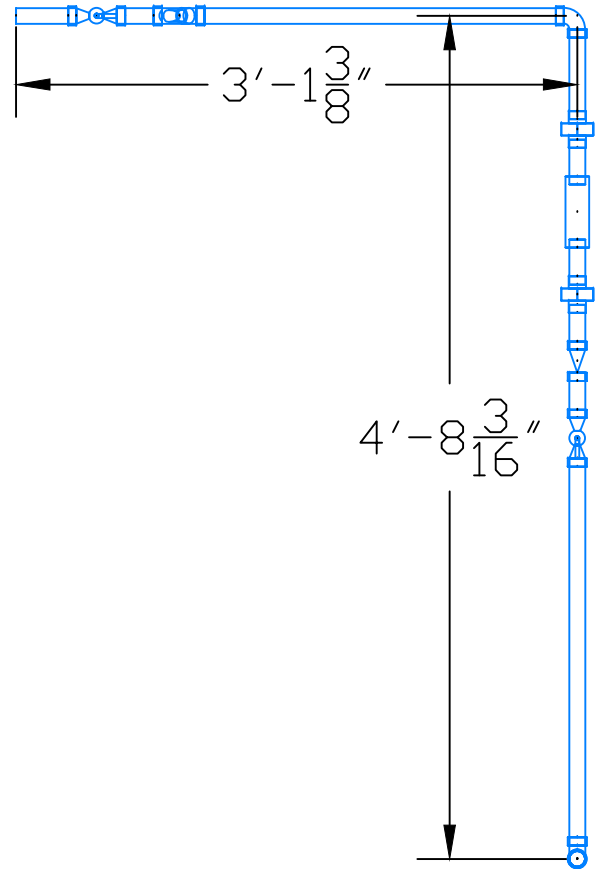

SERVICE	SHOP FABRICATE	X	STEAM,ELECT.TRACE	
HPC	FIELD FABRICATE		INSULATE	
DELGROSSO	BOILER CODE		X RAY	
	HEAVY WALL		STRESS RELIEF	
	ALLOY		COLOUR CODE	
REFERENCE DWG.	Intrepid i Design, LLC. 503 North Twelfth Ave. Altoona, PA. 16601 Phone: (814) 941-4570 Fax: (814) 946-9776			
MAP-3	Coordination Drawings			
	Job No	Drawing Name		Rev
	DELG17	GF-HPC-36		
DATE: 5/25/17	SIZE	SPEC		

Tag	Qty	Size	Sch/Conn	Description	Length
1	2	1/2"	Schedule 80 Threaded	90 Degree Short Radius Elbow	
2	1	1/2"	Schedule 80 Threaded	Pipe	7 3/16"
3	1	1/2"	Schedule 80 Threaded	Apollo 72-100 Ball Valve	
4	5	1/2"	Schedule 80 Threaded	Pipe	5x3'
5	1	1/2"	Schedule 80 Threaded	Milwaukee 510T Check Valve	
6	2	1/2"	Schedule 80 Threaded	Union	
7	1	1/2"	Schedule 80 Threaded	Steam Trap	
8	1	1/2"	Schedule 80 Threaded	Pipe	4 1/16"
9	1	1/2"	Schedule 80 Threaded	Wye Strainer	
10	1	1/2"	Schedule 80 Threaded	Apollo 72-100 Ball Valve	
11	1	1/2"	Schedule 80 Threaded	Pipe	3 1/16"

REVISIONS				
ZONE	REV	DESCRIPTION	DATE	APPROVED

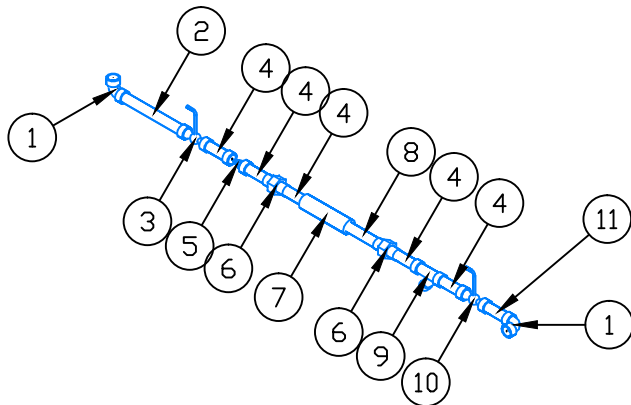
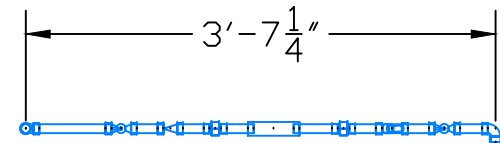

SERVICE	SHOP FABRICATE	X	STEAM,ELECT.TRACE	
HPC	FIELD FABRICATE		INSULATE	
DELGROSSD	BOILER CODE		X RAY	
REFERENCE DWG.	HEAVY WALL		STRESS RELIEF	
MAP-3	ALLOY		COLOUR CODE	
	Intrepid i Design, LLC. 503 North Twelfth Ave. Altoona, PA. 16601 Phone: (814) 941-4570 Fax: (814) 946-9776			
	Job No	Drawing Name		Rev
DATE: 6/14/17	SIZE	GF-HPC-37		
	SPEC	DELG17		

Tag	Qty	Size	Sch/Conn	Description	Length
1	1	1/2"	Schedule 80 Threaded	Pipe	9'-1 15/16"
2	2	1/2"	Schedule 80 Threaded	90 Degree Short Radius Elbow	
3	1	1/2"	Schedule 80 Threaded	Pipe	8'-5 1/4"
4	1	1/2"	Schedule 80 Threaded	Pipe	8"

REVISIONS				
ZONE	REV	DESCRIPTION	DATE	APPROVED

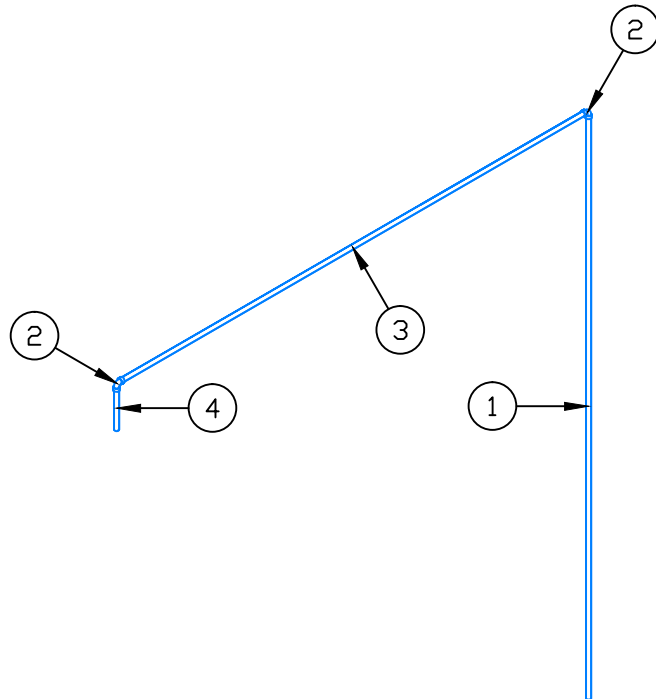
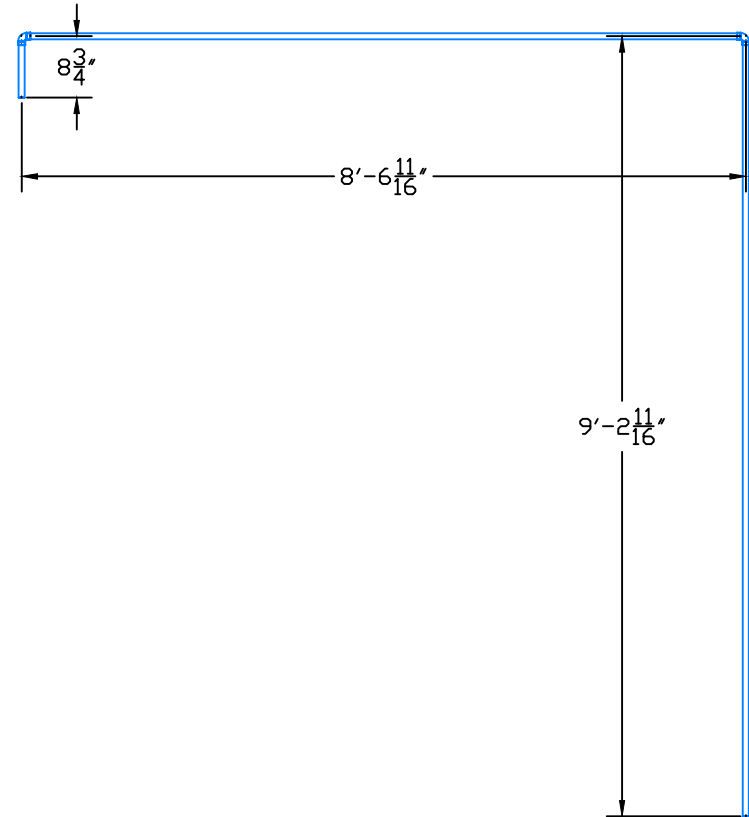

SERVICE	SHOP FABRICATE	X	STEAM,ELECT.TRACE	
HPC	FIELD FABRICATE		INSULATE	
DELGROSSO	BOILER CODE		X RAY	
	HEAVY WALL		STRESS RELIEF	
	ALLOY		COLOUR CODE	
REFERENCE DWG.	Intrepid i Design, LLC. 503 North Twelfth Ave. Altoona, PA. 16601 Coordination Drawings Phone: (814) 941-4570 Fax: (814) 946-9776			
MAP-3	Job No	Drawing Name		Rev
	DELG17	GF-HPC-38		
DATE: 6/14/17	SIZE	SPEC		